

# N-Tron® Series NT5000 Gigabit Managed Ethernet Switches

Hardware Guide | January 2023  
LP1182 | Revision A



## COPYRIGHT

©2023 Red Lion Controls, Inc. All rights reserved. Red Lion, the Red Lion logo, N-Tron, N-View, and N-Ring are trademarks of Red Lion Controls, Inc. All other company and product names are trademarks of their respective owners.

Red Lion Controls, Inc.  
35 Willow Springs Circle  
York, PA 17406

## CONTACT INFORMATION:

### AMERICAS

Inside US: +1 (877) 432-9908  
Outside US: +1 (717) 767-6511  
**Hours:** 8 am-6 pm Eastern Standard Time  
(UTC/GMT -5 hours)

### ASIA-PACIFIC

Shanghai, P.R. China: +86 21-6113-3688 x767  
**Hours:** 9 am-6 pm China Standard Time  
(UTC/GMT +8 hours)

### EUROPE

Netherlands: +31 33-4723-225  
France: +33 (0) 1 84 88 75 25  
Germany: +49 (0) 1 89 5795-9421  
UK: +44 (0) 20 3868 0909  
**Hours:** 9 am-5 pm Central European Time  
(UTC/GMT +1 hour)

Website: [www.redlion.net](http://www.redlion.net)

Support: [support.redlion.net](http://support.redlion.net)

# Table of Contents

<b>Preface</b> .....	<b>1</b>
Disclaimer .....	1
Safety Summary .....	1
Compliance Information .....	1
FCC Statement .....	1
Industry Canada .....	1
Warnings and Cautions .....	2
Conditions of Safe Use per ATEX, IECEx and UKEX .....	2
Informations de conformité .....	2
Déclaration de conformité FCC .....	2
Industry Canada .....	3
Avertissements et mises en garde .....	3
Conditions d'utilisation sûre selon ATEX, IECEx et UKEX .....	3
Regulatory Information .....	4
Trademark Acknowledgments .....	5
Document History and Related Publications .....	5
Additional Product Information .....	5
<b>Chapter 1 Introduction</b> .....	<b>7</b>
Features and Benefits .....	8
NT5006 Specifications .....	9
NT5006 Dimensions In inches [mm] .....	10
NT5006-DM2 Specifications .....	11
NT5006-DM2 Dimensions In inches [mm] .....	12
NT5008 Specifications .....	13
NT5008 Dimensions In inches [mm] .....	14
NT5008-DM2 Specifications .....	15
NT5008-DM2 Dimensions In inches [mm] .....	16
NT5008-FX2 Specifications .....	17
NT5008-FX2 Dimensions In inches [mm] .....	18
NT5008-GX2 Specifications .....	19
NT5008-GX2 Dimensions In inches [mm] .....	20
NT5010-DM2 Specifications .....	21
NT5010-DM2 Dimensions In inches [mm] .....	22
NT5010-FX2 Specifications .....	23
NT5010-FX2 Dimensions In inches [mm] .....	24
NT5010-GX2 Specifications .....	25
NT5010-GX2 Dimensions In inches [mm] .....	26
NT5016 Specifications .....	27
NT5016 Dimensions In inches [mm] .....	28
NT5018-DM2 Specifications .....	29

NT5018-DM2 Dimensions In inches [mm]	30
NT5018-FX2 Specifications	31
NT5018-FX2 Dimensions In inches [mm]	32
NT5018-GX2 Specifications	33
NT5018-GX2 Dimensions In inches [mm]	34
LEDs	35
Transceiver Characteristics	35
100 MB Fiber Transceiver Characteristics (NT5008-FX2, NT5010-FX2, NT5018-FX2)	35
Gigabit Fiber Transceiver Characteristics (NT5008-GX2, NT5010-GX2, NT5018-GX2)	35
SFP 100Base Fiber Transceiver Characteristics (NT5006-DM2, NT5008-DM2, NT5010-DM2, NT5018-DM2)	35
SFP 1000Base Fiber Transceiver Characteristics (NT5006-DM2, NT5008-DM2, NT5010-DM2, NT5018-DM2)	36
<b>Chapter 2 Installation</b>	<b>37</b>
Contents of Package	37
Mounting the NT5000 Unit	37
DIN Rail Mounting Instructions	37
DIN Rail Removal Instructions	38
Panel Mounting NT5000 Models	38
Power Source	39
Connecting to Earth Ground	39
Configurable Alarm Relay Contact	40
Connecting to the Ethernet Port (RJ45 Ethernet)	40
Connecting to the Ethernet Port (Fiber, SFP)	41
USB Interface	41
USB Cable	41
Terminal	42
Cleaning	42
<b>Chapter 3 Accessing the Web Software Interface</b>	<b>43</b>
Ordering Information	44
Accessories	45
<b>Service and Support Information</b>	<b>47</b>
Service Information	47
For Your Convenience:	47
Product Support	47
Limited Warranty	48

# Preface

## Disclaimer

This hardware guide provides an overview of installation, maintenance and operation of the N-Tron® Series NT5000 Gigabit Managed Ethernet Switches equipment. It is not intended as a step-by-step guide or a complete set of all procedures necessary and sufficient to complete all operations.

While every effort has been made to ensure that this document is complete and accurate at the time of release, the information that it contains is subject to change. Red Lion Controls, Inc. is not responsible for any additions to or alterations of the original document. Industrial networks vary widely in their configurations, topologies, and traffic conditions. This document is intended as a general guide only. It has not been tested for all possible applications, and it may not be complete or accurate for some situations.

Users of this document are urged to heed warnings and cautions used throughout the document.

## Safety Summary

All safety related regulations, local codes and instructions that appear in this document or on equipment must be observed to ensure personal safety and to prevent damage to either the device or equipment connected to it.

Do not use these products to replace proper safety interlocking. No software-based device (or any other solid-state device) should ever be designed to be responsible for the maintenance of personnel safety or consequential equipment not equipped with safeguards. Red Lion disclaims any responsibility for damages, either direct or consequential, that result from the use of this equipment in a manner not specified.

## Compliance Information

### FCC Statement

This product complies with Part 15 of the FCC-A Rules.

Operation is subject to the following conditions:

1. This device may not cause harmful Interference
2. This device must accept any interference received, including interference that may cause undesired operation.





**Note:** This equipment has been tested and found to comply with the limits for a Class A digital device, pursuant to Part 15 of the FCC Rules. These limits are designed to provide reasonable protection against harmful interference in a residential installation. This equipment generates, uses, and can radiate radio frequency energy and, if not installed and used in accordance with the instructions, may cause harmful interference to radio communications. Operation of this device in a residential area is likely to cause harmful interference in which case the user will be required to correct the interference at his/her own expense.

### Industry Canada

This Class A digital apparatus meets all requirements of the Canadian Interference Causing Equipment Regulations. Operation is subject to the following two conditions; (1) this device may not cause harmful interference, and (2) this device must accept any interference received, including interference that may cause undesired operation.

## Warnings and Cautions

Warnings apply to situations where personal injury or death may result.  
Cautions apply to where reduced function or damage to equipment may result.

	<p><b>CAUTION:</b> Risk of Danger</p> <p>Read complete instructions prior to installation and operation of the unit.</p> <p><b>CAUTION:</b> If equipment is used in a manner not specified by Red Lion, the protection provided by the equipment may be impaired.</p> <p><b>CAUTION:</b> Do not perform any services on the unit unless qualified to do so. Do not substitute unauthorized parts or make unauthorized modifications to the unit.</p> <p><b>WARNING - EXPLOSION HAZARD</b> - Do not disconnect equipment unless power has been switched off or area is known to be non-hazardous.</p>
	<p><b>WARNING:</b> Properly ground the unit before connecting anything else to the unit. Units not properly grounded may result in a safety risk and could be hazardous and may void the warranty.</p> <p><b>CAUTION:</b> Observe proper DC Voltage polarity when installing power input cables. Reversing voltage polarity can cause permanent damage to the unit and voids the warranty.</p>
	<p><b>DANGER:</b> Class 1 Laser Product. Do not stare into the laser.</p>
	<p><b>DANGER:</b> Hot Surface.</p> <p>During operation, take care to avoid coming into contact with a hot surface. Do not touch it over 1 second.</p>

## Conditions of Safe Use per ATEX, IECEx and UKEX

- The equipment shall only be used in an area of at least pollution degree 2, as defined in EN IEC 60664-1.
- The equipment shall be installed in an enclosure that provides a minimum ingress protection of IP 54 in accordance with EN IEC 60079-0.
- The equipment is open-type and intended to be installed in suitable, tool accessible external enclosure to provide fire, shock, mechanical and environmental protections. The enclosure shall be tool accessible and suitable for the location.

Transient protection shall be provided that is set at a level not exceeding 140 % of the peak rated voltage value at the supply terminals to the equipment.

## Informations de conformité

### Déclaration de conformité FCC

Ce produit est conforme à la partie 15 des règles de la FCC-A

Utilisation est soumise aux conditions suivantes:

1. Ce dispositif ne doit pas causer des interférences nuisibles
2. Cet appareil doit accepter toute interférence reçue, y compris les interférences qui peuvent causer un mauvais fonctionnement.





**Note:** Cet équipement a été testé et jugé conforme aux limites de la classe A des appareils numériques, conformément à la partie 15 des règles de la FCC . Ces limites sont conçues pour fournir une protection raisonnable contre les interférences nuisibles dans une installation résidentielle. Cet équipement génère, utilise et peut émettre de l'énergie radiofréquence et, si il n'est pas installé et utilise conformément aux instructions, peut causer des interférences nuisibles aux communications radio. L'utilisation de cet appareil dans une zone résidentielle est susceptible de provoquer des interférences nuisibles, auquel cas l'utilisateur sera tenu de corriger les interférences à ses propres frais.

## Industry Canada

Cet appareillage numérique de la classe A répond à toutes les exigences de l'interférence canadienne causant des règlements d'équipement. L'opération est sujette aux deux conditions suivantes: (1) ce dispositif peut ne pas causer l'interférence nocive, et (2) ce dispositif doit accepter n'importe quelle interférence reçue, y compris l'interférence qui peut causer l'opération peu désirée.

## Avertissements et mises en garde

Les avertissements s'appliquent à des situations pouvant entraîner des blessures ou la mort.  
Les mises en garde s'appliquent dans les cas où une réduction du fonctionnement ou des dommages à l'équipement peuvent en résulter.

	<p><b>ATTENTION:</b> Risque de danger</p> <p>Lire les instructions complètes avant l'installation et l'utilisation de l'appareil.</p> <p><b>ATTENTION:</b> Si équipement est utilisé d'une manière non spécifiée par Red Lion, la protection fournie par l'équipement peut être compromise.</p> <p><b>ATTENTION:</b> Ne pas effectuer de services sur l'appareil s'il n'est pas qualifié pour le faire. Ne pas substituer pièces non autorisées ou de modifications non autorisées de l'appareil.</p> <p><b>AVERTISSEMENT - DANGER D'EXPLOSION</b> - Ne pas débrancher l'équipement à moins que l'alimentation électrique n'ait été coupée ou que la zone ne soit connue comme étant non dangereuse.</p>
	<p><b>ALERTE:</b> Correctement à la terre de l'unité avant tout raccordement à l'unité. Unités pas correctement mise à la terre peut entraîner un risque de sécurité et pourraient être dangereux et peut annuler la garantie. not properly grounded may result in a safety risk and could be hazardous and may void the warranty.</p> <p><b>ATTENTION:</b> Respecter la polarité correcte de tension DC lors de l'installation des câbles d'alimentation d'entrée. Inversion de polarité de tension peut causer des dommages permanents à l'appareil et annule la garantie.</p>
	<p><b>AVERTISSEMENT:</b> Produit Laser Classe 1. Ne regardez pas dans le laser.</p>
	<p><b>AVERTISSEMENT:</b> Surface chaude!</p> <p>Pendant l'opération, en prenant soin d'éviter d'entrer en contact avec une surface chaude. Ne le touchez pas plus d'une seconde.</p>

## Conditions d'utilisation sûre selon ATEX, IECEx et UKEX

- L'équipement ne doit être utilisé que dans une zone présentant au moins un degré de pollution 2, tel que défini dans la norme EN IEC 60664-1.
- L'équipement doit être installé dans un boîtier offrant une protection minimale contre les intrusions de IP 54, conformément à la norme EN IEC 60079-0.
- L'équipement est de type ouvert et doit être installé dans un boîtier externe approprié, accessible avec un outil, afin de fournir des protections contre le feu, les chocs, la mécanique et l'environnement. Le boîtier doit être accessible aux outils et adapté à l'emplacement.

Une protection contre les transitoires doit être fournie, réglée à un niveau ne dépassant pas 140 % de la valeur de la tension nominale de pointe aux bornes d'alimentation de l'équipement.

## Regulatory Information

<b>Product Safety</b>
UL 61010 and C22.2 No. 61010 Ordinary Locations
UL 121201 and CSA C22.2 No. 213 Class I, Division 2 Hazardous Locations
ATEX, IECEX and UKEx
Ⓜ II 3 G Ex ec nC IIC T4 Gc
UL 20 ATEX 2645X
UL 22.0038X IECEX
UL22UKEX2346X
<b>EMI/EMC</b>
CFR 47, Part 15, Subpart B
Innovation, Science and Economic Development Canada ICES-003 Issue 6
ANSI C63.4
EN 61000-6-2 Generic standards - Immunity standard for industrial environments
EN 61000-6-4 Generic standards - Emission standard for industrial environments
IEC 61000-4-2 (ESD)
IEC 61000-4-3 (Radio-Frequency Electromagnetic Field)
IEC 61000-4-4 (Fast Transient)
IEC 61000-4-5 (Surge)
IEC 61000-4-6 (Radio-Frequency Continuous Conducted)
IEC 61000-4-8 (Power Frequency Magnetic Field)
<b>Shock &amp; Vibration</b>
IEC 68-2-27: 200 g @ 10 ms Triaxial; non-operational; panel mounted
IEC 68-2-6: 15 g @ 5-200 Hz Triaxial; operational; panel mounted
<b>Railway/Rolling Stock</b>
EN 50155, EN 50121 and EN 61373
<b>Marine</b>
ABS Type Approval for Shipboard Applications
<b>Designed to Comply With</b>
IEEE 1613 for Electric Utility Substations
NEMA TS1/TS2 for Traffic Control
<b>Other</b>
RoHS compliant



## Trademark Acknowledgments

Red Lion Controls acknowledges and recognizes ownership of the following trademarked terms used in this document.

- Ethernet™ is a registered trademark of Xerox Corporation.

All other company and product names are trademarks of their respective owners.

## Document History and Related Publications

The hard copy and electronic media versions of this document are revised only at major releases and therefore, may not always contain the latest product information. Tech Notes and/or product addendums will be provided as needed between major releases to describe any new information or document changes.

The latest online version of this document can be accessed through the Red Lion website at

[www.redlion.net/support/documentation](http://www.redlion.net/support/documentation).

## Additional Product Information

Additional product information can be obtained by contacting the local sales representative or Red Lion through the contact numbers and/or support website address listed on the inside of the front cover.



# Chapter 1 Introduction

The NT5000 Gigabit Industrial Ethernet Managed switches offer compact, hardened solutions for reliable operation in harsh industrial applications.

Designed for quick installation and ease of use, the NT5000 switches provide a modern graphical user interface with a quick start wizard to assist administrators through configuration for fast and easy deployment.

Graphical dashboards and a logical view of the switch provide status and diagnostic information in easy to read color-coded gauges, so network engineers can quickly assess conditions that may disrupt network stability.

The NT5000 rugged feature-set includes:

- Wide operating temperature range up to -40 °C to 85 °C (model dependent)
- Redundant power inputs (10-49 VDC)
- Shock: IEC 68-2-27: 200 g @ 10 ms Triaxial; non-operational; panel mounted
- Vibration: IEC 68-2-6: 15 g @ 5-200 Hz Triaxial; operational; panel mounted
- Fast boot (traffic passes <20 seconds)
- Configurable alarm contact
- Configurable bi-color fault status LED
- LED port status indicators
- Reverse polarity protection
- ESD and surge protection

The NT5000 is available in 6, 8, 10, 16 and 18 port configurations.

MODEL	10/100/1000BaseT RJ45 PORTS	DUAL MODE (100/1000Base) SFP PORTS	100Base FIBER PORTS	1000Base FIBER PORTS
NT5006	6			
NT5006-DM2	4	2		
NT5008	8			
NT5008-DM2	6	2		
NT5008-FX2	6		2	
NT5008-GX2	6			2
NT5010-DM2	8	2		
NT5010-FX2	8		2	
NT5010-GX2	8			2
NT5016	16			
NT5018-DM2	16	2		
NT5018-FX2	16		2	
NT5018-GX2	16			2

Visit [www.redlion.net](http://www.redlion.net) for detailed model specifications.

For a complete list of features and certifications, see page 8. Additional information is also available in the NT5000 Software User's Guide.

## Features and Benefits

### HARDWARE FEATURES

- Compact, space saving, hardened industrial design
- Wide operating temperature
- High shock and vibration tolerance
  - Shock: IEC 68-2-27: 200 g @ 10 ms Triaxial; non-operational; panel mounted
  - Vibration: IEC 68-2-6: 15 g @ 5-200 Hz Triaxial; operational; panel mounted
- Reverse polarity protection
- ESD and surge protection
- Fast boot (traffic passes < 20 seconds)
- Configurable alarm contact
- Configurable bi-color fault status LED
- LED port status indicators
- Jumbo frame support
- Redundant power inputs (10-49 VDC)
- Hardened industrial design
- IEEE 802.3 compliance
- Full wire speed communication
- MDIX auto-sensing cable
- Auto-sensing speed and flow control
- Latency (typical): < 1.8 µs
- VLAN Address Support: Up to 4k

### MANAGEMENT

- Modern, intuitive Web Interface
  - Configuration wizard
  - Graphical dashboard and logical view of the switch
- Command Line Interface
- Port control
- IGMP v1/v2/v3 auto-configuration
- SNMP v1/v2/v3
- NTP
- 802.1Q tag VLAN and port VLAN
- IEEE 802.1p QoS and port QoS
- DHCP client
- Text-based configuration file
- File transfer: HTTP/HTTPS, TFTP, SNMP

### SECURITY FEATURES

- SSH, SSL, HTTPS
- MAC Filtering
- IEEE 802.1X with RADIUS remote server authentication
- Port/User lockout after failed authentication attempts
- SNMPv3

- Password encryption

### DIAGNOSTIC FEATURES

- Port mirroring
- Event log/Syslog
- LLDP
- Advanced cable diagnostics

### NETWORK REDUNDANCY

- RSTP/MSTP
- Port trunking/LACP
- N-Ring™ auto-member

### MIBS

- RFC 2674 VLAN MIB
- RFC 2819 RMON (Group 1, 2, 3 & 9)
- RFC 1213 MIB II
- RFC 1215 TRAPS MIB
- RFC 4188 Bridge MIB
- RFC 4292 IP Forwarding Table MIB
- RFC 4293 Management Information Base for the Internet Protocol (IP)
- RFC 5519 Multicast Group Membership Discovery MIB
- RFC 2863 Interface Group MIB using SMI v2
- RFC 4133 Entity MIB version 3
- RFC 3411 SNMP Management Frameworks
- RFC 3414 User-based Security Model for SNMPv3
- RFC 3415 View-based access Control Model for SNMP
- IEEE 802.1AB LLDP-MIB
- IEEE 802.1 MSTP MIB

### SOFTWARE TOOL TO MANAGE/SCHEDULE FIRMWARE UPDATES

- N-View™ 2

### REGULATORY CERTIFICATIONS

- Product Safety: UL 61010 and C22.2 No. 61010 OrdLoc, UL 121201 and CSA C22.2 No. 213 Class I, Division 2 HazLoc, ATEX, IECEx and UKEx II 3 G Ex ec nC IIC T4 Gc, UL 20 ATEX 2645X, UL 22.0038X IECEx and UL22UKEX2346X
- EMI/EMC: CFR 47, Part 15, Subpart B, Canada ICES-003, ANSI C63.4, EN 61000-6-2 and 4, IEC 61000-4-2, 3, 4, 5, 6 and 8
- ATEX/IECEx
- Marine: ABS Type Approval for Shipboard Applications DNV (pending)
- Railway/Rolling Stock: EN 50155, EN 50121, EN 61373
- Designed to Comply With - IEEE 1613 for Electric Utility Substations and NEMA TS1/TS2 for Traffic Control
- Other - RoHS compliant



## NT5006 Specifications

MECHANICAL						
MTBF	Ingress Protection	Height	Width	Depth	Weight	Installation Options
1.5M Hours	IP20	3.85" (97.8 mm)	1.65" (41.9 mm)	5.11" (129.8 mm)	1.09 lbs. (0.50 kg)	DIN rail or optional panel mount
POWER						
Power Input Options	Input Voltage Range	Steady Input Range	BTU/hr			
Redundant Input Terminals; Reverse Polarity Protection	10-49 VDC	0.23 A @ 24 VDC	18.84			
ENVIRONMENTAL AND COMPLIANCES						
Operating Temperature Range	Storage Temperature Range	Humidity (non-condensing)	Operating Altitude			
-40 to 85 °C	-40 to 85 °C	10 to 95% RH	0 to 10,000 ft.			
SHOCK AND VIBRATION						
Shock			Vibration			
IEC 68-2-27: 200 g @ 10 ms Triaxial; non-operational; panel mounted			IEC 68-2-6: 15 g @ 5-200 Hz Triaxial; operational; panel mounted			
CONNECTORS						
10/100/1000BaseT	Six (6) RJ45 copper ports					
NETWORK MEDIA						
10BaseT	≥Cat3 Cable					
100BaseTX	≥Cat5 Cable					
1000BaseT	≥Cat5e Cable					
NETWORK THROUGHPUT						
Maximum Throughput	Up to 12.0 Gb/s					
MAC ADDRESSES						
MAC Address Support	Up to 4k					
RECOMMENDED MINIMUM WIRING CLEARANCE						
Front	2" (50.8 mm)					
Top	4" (101.6 mm)					

## NT5006 DIMENSIONS In inches [mm]

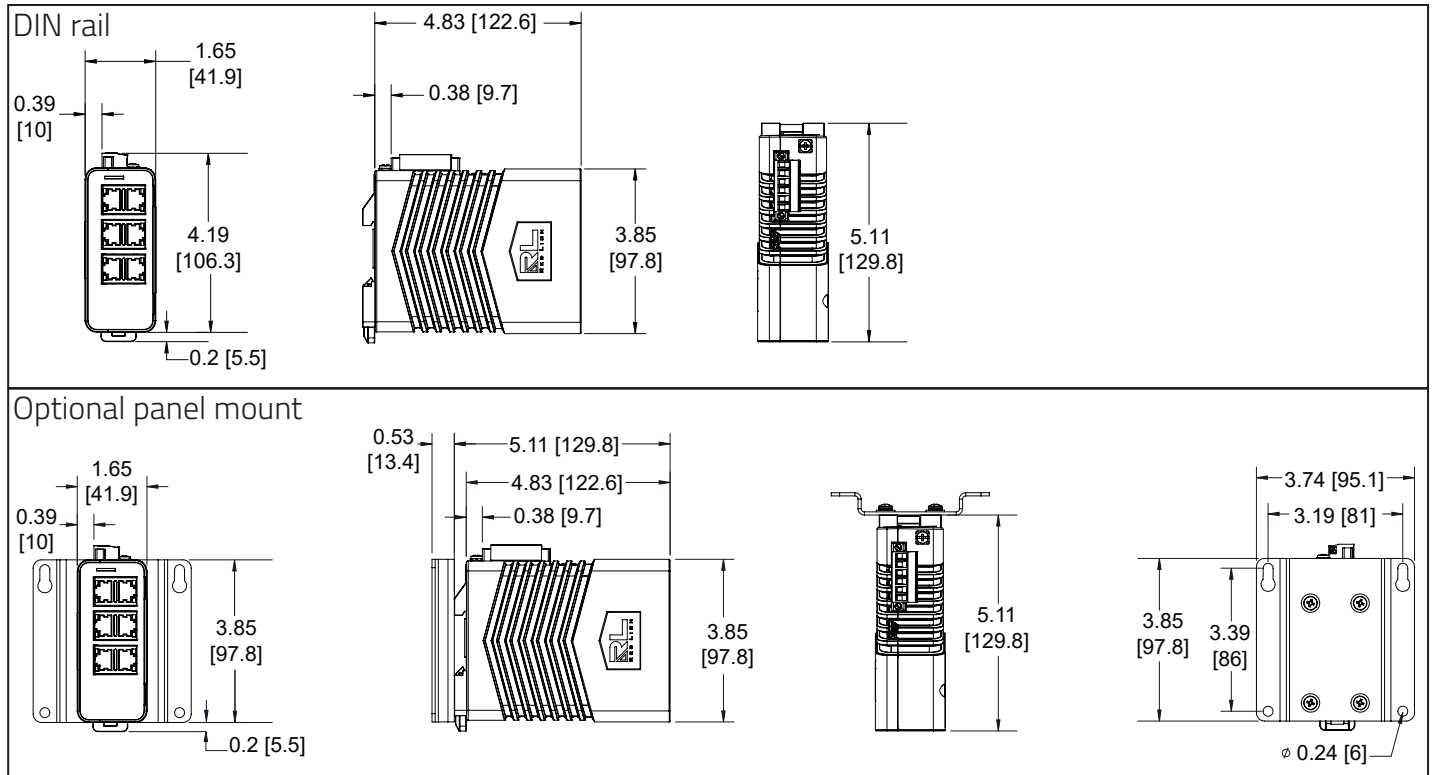

## NT5006-DM2 Specifications

MECHANICAL						
MTBF	Ingress Protection	Height	Width	Depth	Weight	Installation Options
1.5M Hours	IP20	3.85" (97.8 mm)	1.65" (41.9 mm)	5.11" (129.8 mm)	1.13 lbs. (0.51 kg)	DIN rail or optional panel mount
POWER INPUT						
Power Input Options	Input Voltage Range	Steady Input Range	BTU/hr			
Redundant Input Terminals; Reverse Polarity Protection	10-49 VDC	0.29 A @ 24 VDC	23.75			
ENVIRONMENTAL AND COMPLIANCES						
Operating Temperature Range	Storage Temperature Range	Humidity (non-condensing)	Operating Altitude			
-40 to 85 °C	-40 to 85 °C	10 to 95% RH	0 to 10,000 ft.			
SHOCK AND VIBRATION						
Shock			Vibration			
IEC 68-2-27: 200 g @ 10 ms Triaxial; non-operational; panel mounted			IEC 68-2-6: 15 g @ 5-200 Hz Triaxial; operational; panel mounted			
CONNECTORS						
10/100/1000BaseT		Four (4) RJ45 copper ports				
Dual Mode 100/1000Base SFP Port		Up to two (2) SFP port transceivers (SFP transceivers sold separately)				
NETWORK MEDIA						
10BaseT		≥Cat3 Cable				
100BaseTX		≥Cat5 Cable				
1000BaseT		≥Cat5e Cable				
100BaseFX, 1000BaseSX Multimode		50-62.5/125µm				
100BaseFX, 1000BaseLX Singlemode		7-10/125µm				
NETWORK THROUGHPUT						
Maximum Throughput		Up to 12.0 Gb/s				
MAC ADDRESSES						
MAC Address Support		Up to 4k				
RECOMMENDED MINIMUM WIRING CLEARANCE						
Front		4" (101.6 mm)				
Top		4" (101.6 mm)				

## NT5006-DM2 DIMENSIONS In inches [mm]

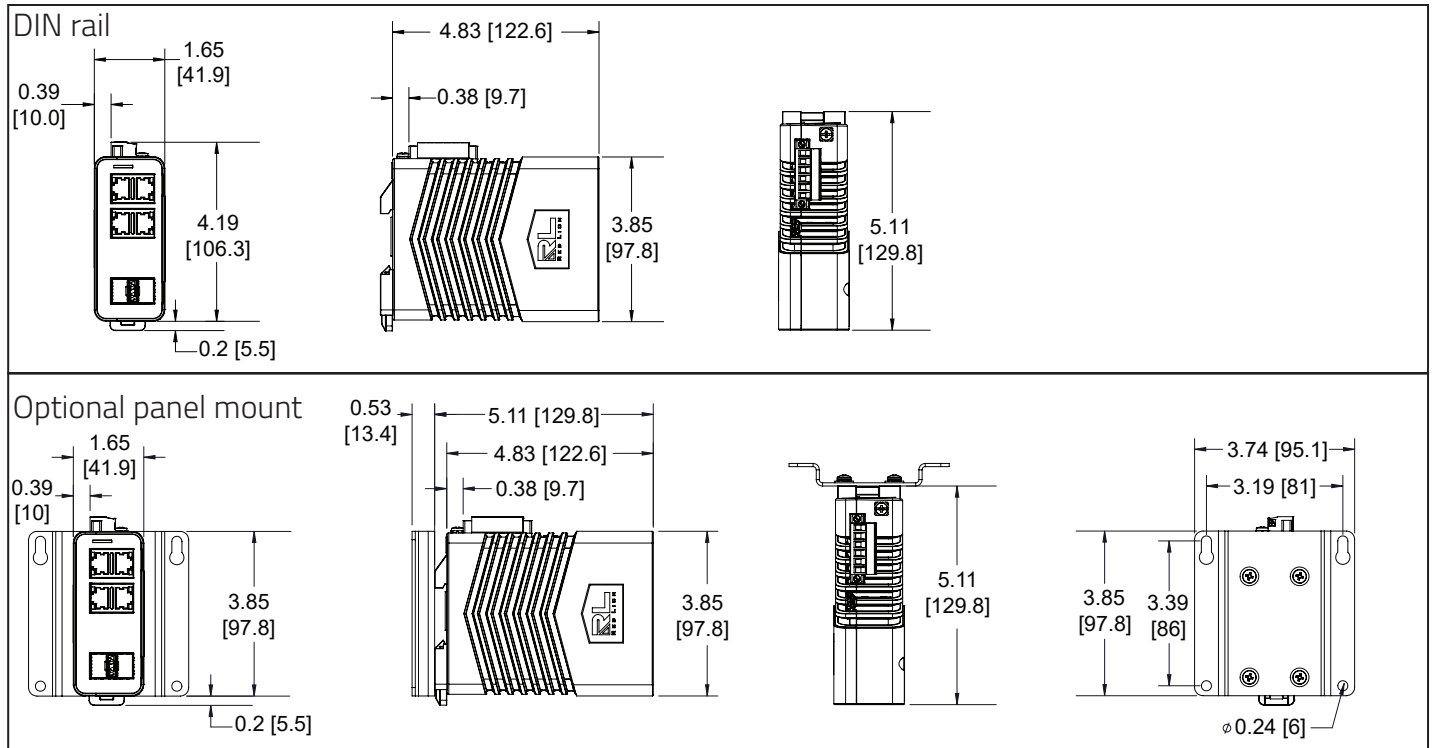



## NT5008 Specifications

MECHANICAL						
MTBF	Ingress Protection	Height	Width	Depth	Weight	Installation Options
1.5M Hours	IP20	3.85" (97.8 mm)	1.65" (41.9 mm)	5.11" (129.8 mm)	1.09 lbs. (0.50 kg)	DIN rail or optional panel mount
POWER						
Power Input Options	Input Voltage Range	Steady Input Range	BTU/hr			
Redundant Input Terminals; Reverse Polarity Protection	10-49 VDC	0.26 A @ 24 VDC	21.29			
ENVIRONMENTAL AND COMPLIANCES						
Operating Temperature Range	Storage Temperature Range	Humidity (non-condensing)	Operating Altitude			
-40 to 85 °C	-40 to 85 °C	10 to 95% RH	0 to 10,000 ft.			
SHOCK AND VIBRATION						
Shock			Vibration			
IEC 68-2-27: 200 g @ 10 ms Triaxial; non-operational; panel mounted			IEC 68-2-6: 15 g @ 5-200 Hz Triaxial; operational; panel mounted			
CONNECTORS						
10/100/1000BaseT	Eight (8) RJ45 copper ports					
NETWORK MEDIA						
10BaseT	≥Cat3 Cable					
100BaseTX	≥Cat5 Cable					
1000BaseT	≥Cat5e Cable					
NETWORK THROUGHPUT						
Maximum Throughput	Up to 16.0 Gb/s					
MAC ADDRESSES						
MAC Address Support	Up to 4k					
RECOMMENDED MINIMUM WIRING CLEARANCE						
Front	2" (50.8 mm)					
Top	4" (101.6 mm)					

## NT5008 DIMENSIONS In inches [mm]

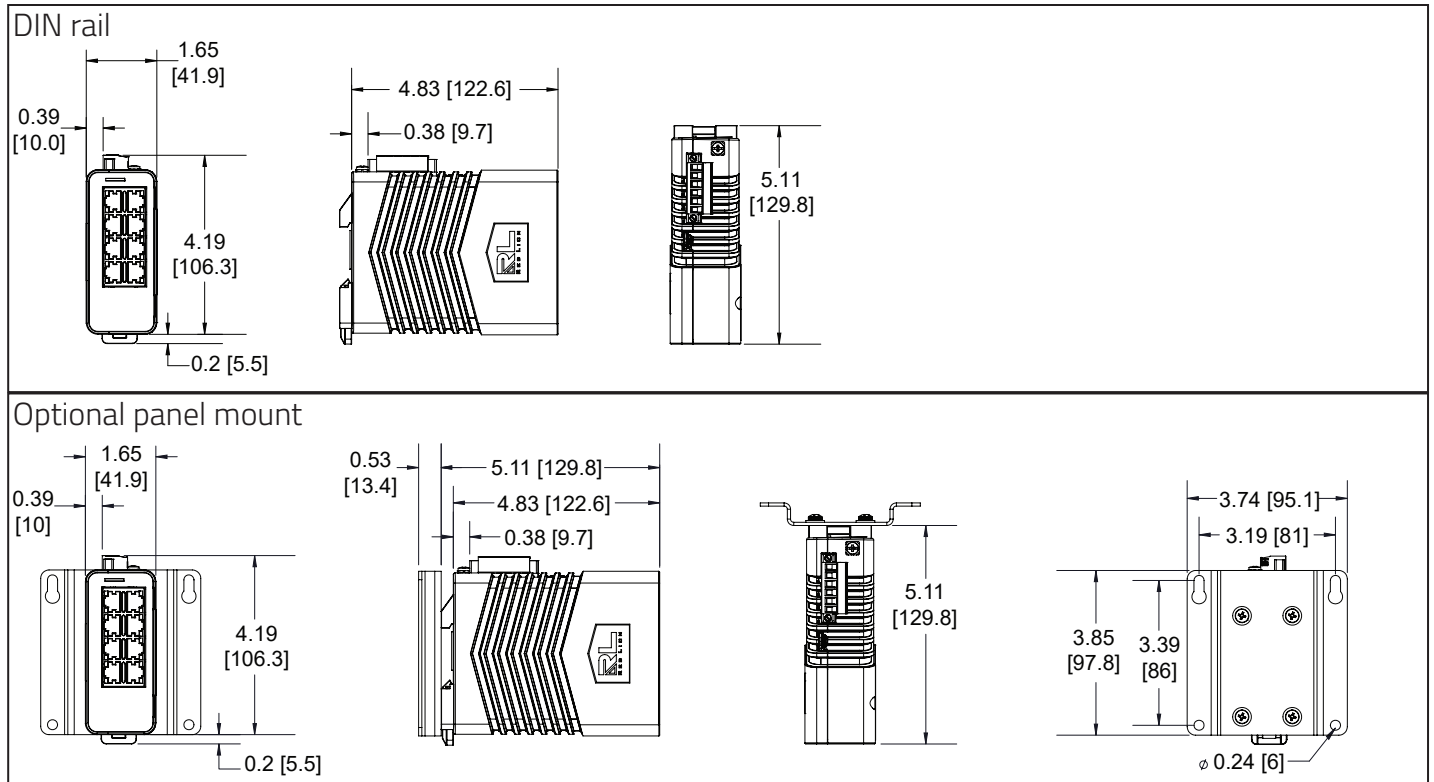

## NT5008-DM2 Specifications

MECHANICAL						
MTBF	Ingress Protection	Height	Width	Depth	Weight	Installation Options
1.5M Hours	IP20	3.85" (97.8 mm)	1.65" (41.9 mm)	5.11" (129.8 mm)	1.16 lbs. (0.52 kg)	DIN rail or optional panel mount
POWER INPUT						
Power Input Options	Input Voltage Range	Steady Input Range	BTU/hr			
Redundant Input Terminals; Reverse Polarity Protection	10-49 VDC	0.35 A @ 24 VDC	28.66			
ENVIRONMENTAL AND COMPLIANCES						
Operating Temperature Range	Storage Temperature Range	Humidity (non-condensing)	Operating Altitude			
-40 to 85 °C	-40 to 85 °C	10 to 95% RH	0 to 10,000 ft.			
SHOCK AND VIBRATION						
Shock			Vibration			
IEC 68-2-27: 200 g @ 10 ms Triaxial; non-operational; panel mounted			IEC 68-2-6: 15 g @ 5-200 Hz Triaxial; operational; panel mounted			
CONNECTORS						
10/100/1000BaseT		Six (6) RJ45 copper ports				
Dual Mode 100/1000Base SFP Port		Up to two (2) SFP port transceivers (SFP transceivers sold separately)				
NETWORK MEDIA						
10BaseT		≥Cat3 Cable				
100BaseTX		≥Cat5 Cable				
1000BaseT		≥Cat5e Cable				
100BaseFX, 1000BaseSX Multimode		50-62.5/125µm				
100BaseFX, 1000BaseLX Singlemode		7-10/125µm				
NETWORK THROUGHPUT						
Maximum Throughput		Up to 16.0 Gb/s				
MAC ADDRESSES						
MAC Address Support		Up to 4k				
RECOMMENDED MINIMUM WIRING CLEARANCE						
Front		4" (101.6 mm)				
Top		4" (101.6 mm)				

## NT5008-DM2 DIMENSIONS In inches [mm]

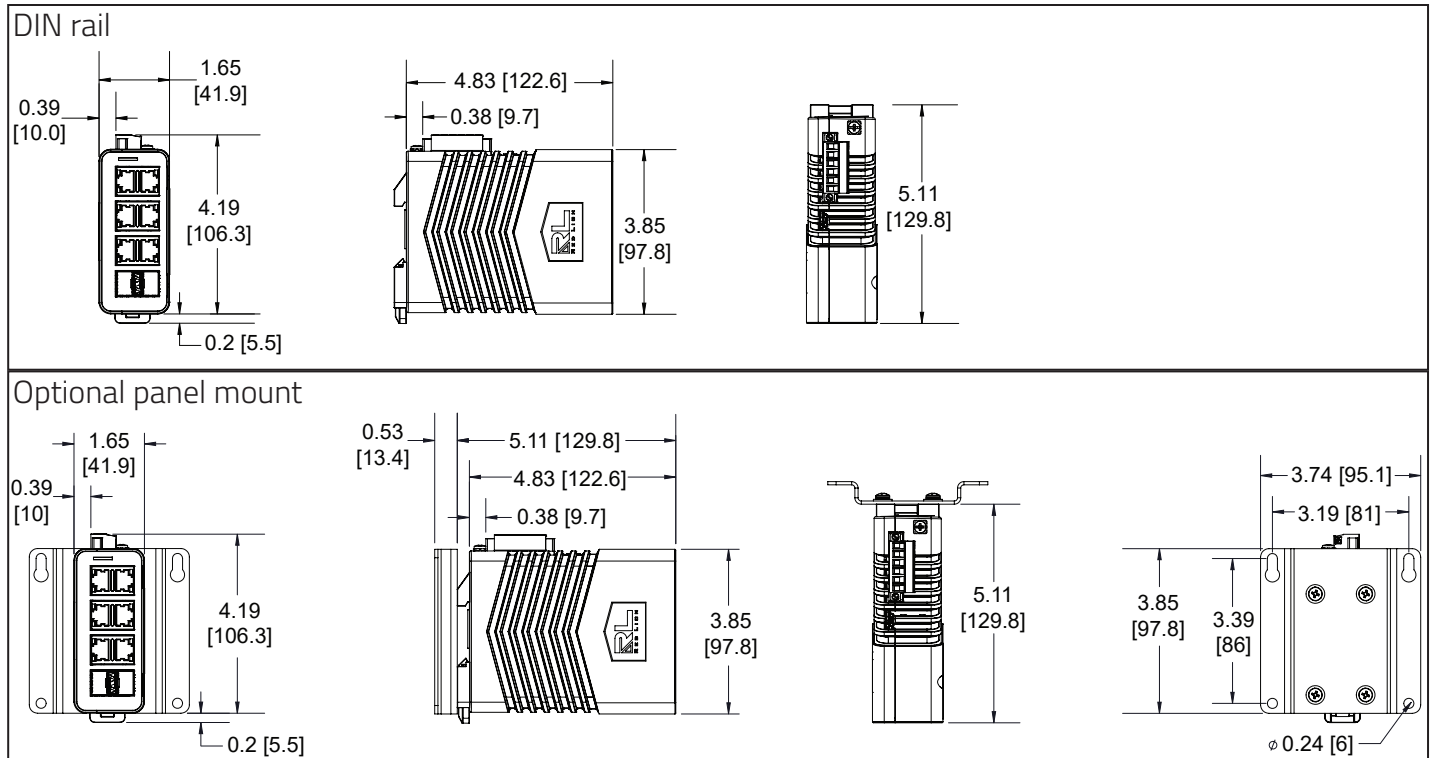

## NT5008-FX2 Specifications

MECHANICAL						
MTBF	Ingress Protection	Height	Width	Depth	Weight	Installation Options
1.2M Hours	IP20	3.85" (97.8 mm)	2.25" (57.1 mm)	5.11" (129.8 mm)	1.38 lbs. (0.62 kg)	DIN rail or optional panel mount
POWER INPUT						
Power Input Options	Input Voltage Range	Steady Input Range	BTU/hr			
Redundant Input Terminals; Reverse Polarity Protection	10-49 VDC	0.26 A @ 24 VDC	21.29			
ENVIRONMENTAL AND COMPLIANCES						
Operating Temperature Range	Storage Temperature Range	Humidity (non-condensing)	Operating Altitude			
-40 to 85 °C	-40 to 85 °C	10 to 95% RH	0 to 10,000 ft.			
SHOCK AND VIBRATION						
Shock			Vibration			
IEC 68-2-27: 200 g @ 10 ms Triaxial; non-operational; panel mounted			IEC 68-2-6: 15 g @ 5-200 Hz Triaxial; operational; panel mounted			
CONNECTORS						
10/100/1000BaseT	Six (6) RJ45 copper ports					
100BaseFX	Two (2) SC or ST duplex fiber ports					
NETWORK MEDIA						
10BaseT	≥Cat3 Cable					
100BaseTX	≥Cat5 Cable					
1000BaseT	≥Cat5e Cable					
100BaseFX Multimode	50-62.5/125 μm					
100BaseFX Singlemode	7-10/125 μm					
NETWORK THROUGHPUT						
Maximum Throughput	Up to 12.4 Gb/s					
MAC ADDRESSES						
MAC Address Support	Up to 4k					
RECOMMENDED MINIMUM WIRING CLEARANCE						
Front	4" (101.6 mm)					
Top	4" (101.6 mm)					

## NT5008-FX2 DIMENSIONS In inches [mm]

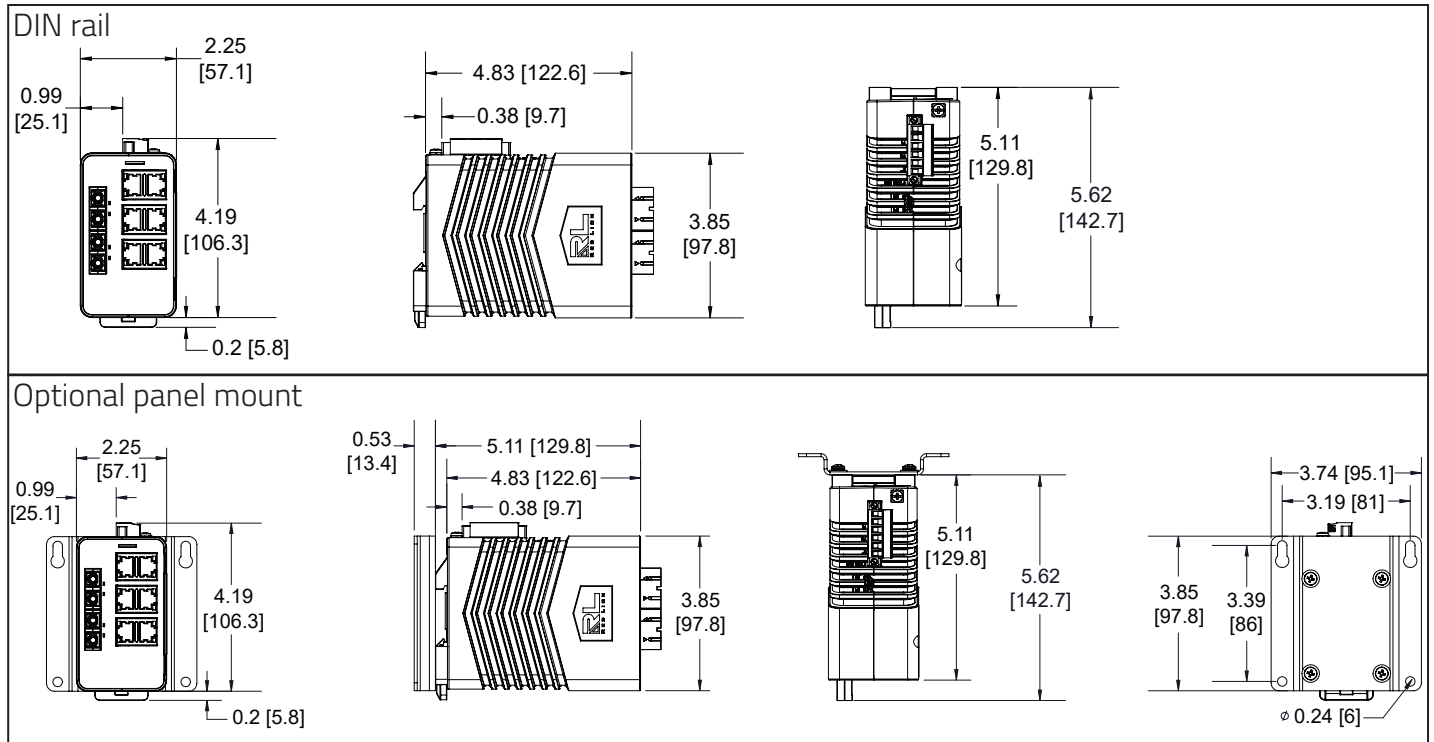

## NT5008-GX2 Specifications

MECHANICAL						
MTBF	Ingress Protection	Height	Width	Depth	Weight	Installation Options
1.2M Hours	IP20	3.85" (97.8 mm)	2.25" (57.1 mm)	5.11" (129.8 mm)	1.38 lbs. (0.62 kg)	DIN rail or optional panel mount
POWER INPUT						
Power Input Options	Input Voltage Range	Steady Input Range	BTU/hr			
Redundant Input Terminals; Reverse Polarity Protection	10-49 VDC	0.26 A @ 24 VDC	21.29			
ENVIRONMENTAL AND COMPLIANCES						
Operating Temperature Range	Storage Temperature Range	Humidity (non-condensing)	Operating Altitude			
-40 to 85 °C	-40 to 85 °C	10 to 95% RH	0 to 10,000 ft.			
SHOCK AND VIBRATION						
Shock			Vibration			
IEC 68-2-27: 200 g @ 10 ms Triaxial; non-operational; panel mounted			IEC 68-2-6: 15 g @ 5-200 Hz Triaxial; operational; panel mounted			
CONNECTORS						
10/100/1000BaseT	Six (6) RJ45 copper ports					
1000BaseFiber	Two (2) SC duplex fiber ports					
NETWORK MEDIA						
10BaseT	≥Cat3 Cable					
100BaseTX	≥Cat5 Cable					
1000BaseT	≥Cat5e Cable					
1000BaseFX Multimode	50-62.5/125 μm					
1000BaseFX Singlemode	7-10/125 μm					
NETWORK THROUGHPUT						
Maximum Throughput	Up to 16.0 Gb/s					
MAC ADDRESSES						
MAC Address Support	Up to 4k					
RECOMMENDED MINIMUM WIRING CLEARANCE						
Front	4" (101.6 mm)					
Top	4" (101.6 mm)					

## NT5008-GX2 DIMENSIONS In inches [mm]

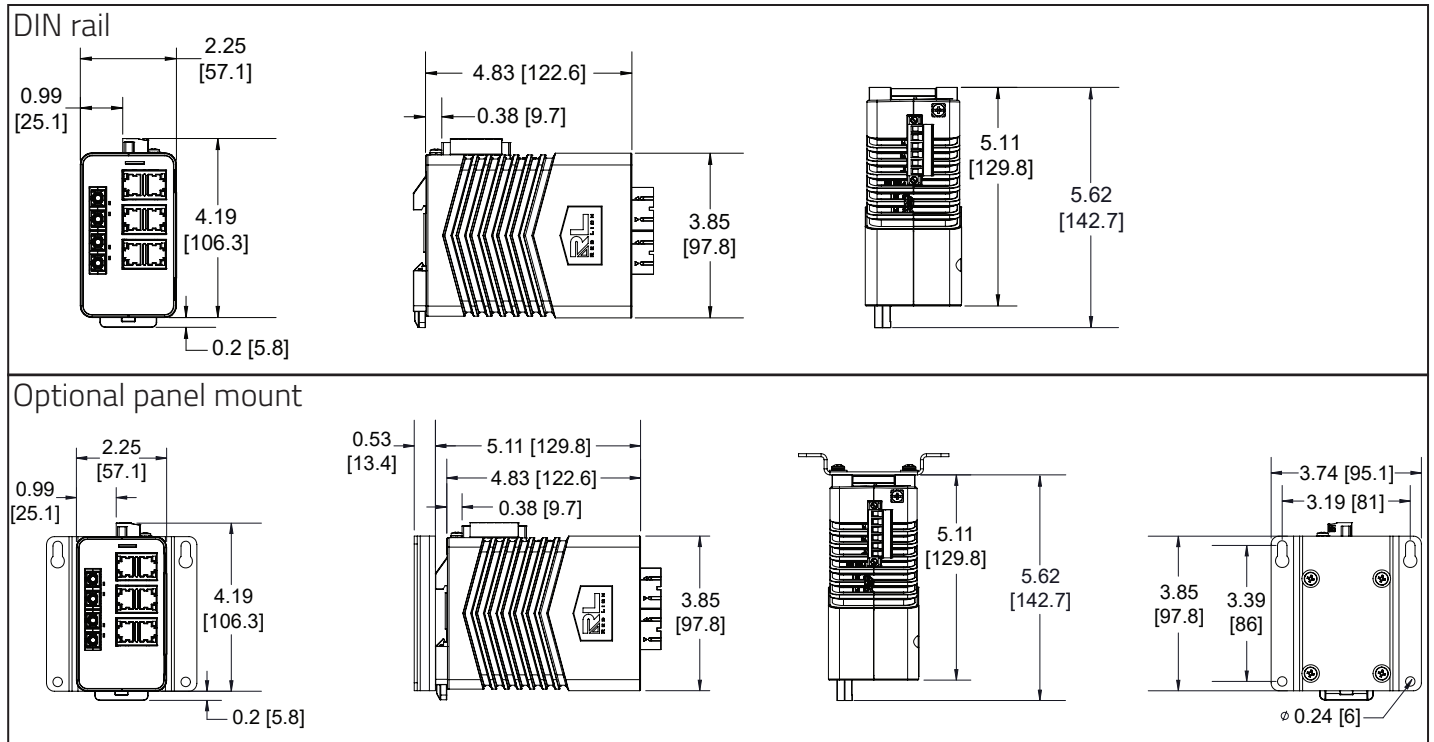



## NT5010-DM2 Specifications

MECHANICAL						
MTBF	Ingress Protection	Height	Width	Depth	Weight	Installation Options
1.5M Hours	IP20	3.85" (97.8 mm)	1.65" (41.9 mm)	5.11" (129.8 mm)	1.16 lbs. (0.52 kg)	DIN rail or optional panel mount
POWER INPUT						
Power Input Options	Input Voltage Range	Steady Input Range	BTU/hr			
Redundant Input Terminals; Reverse Polarity Protection	10-49 VDC	0.39 A @ 24 VDC	31.94			
ENVIRONMENTAL AND COMPLIANCES						
Operating Temperature Range	Storage Temperature Range	Humidity (non-condensing)	Operating Altitude			
-40 to 85 °C	-40 to 85 °C	10 to 95% RH	0 to 10,000 ft.			
SHOCK AND VIBRATION						
Shock			Vibration			
IEC 68-2-27: 200 g @ 10 ms Triaxial; non-operational; panel mounted			IEC 68-2-6: 15 g @ 5-200 Hz Triaxial; operational; panel mounted			
CONNECTORS						
10/100/1000BaseT		Eight (8) RJ45 copper ports				
Dual Mode 100/1000Base SFP Port		Up to two (2) SFP port transceivers (SFP transceivers sold separately)				
NETWORK MEDIA						
10BaseT		≥Cat3 Cable				
100BaseTX		≥Cat5 Cable				
1000BaseT		≥Cat5e Cable				
100BaseFX, 1000BaseSX Multimode		50-62.5/125µm				
100BaseFX, 1000BaseLX Singlemode		7-10/125 µm				
NETWORK THROUGHPUT						
Maximum Throughput		Up to 20.0 Gb/s				
MAC ADDRESSES						
MAC Address Support		Up to 4k				
RECOMMENDED MINIMUM WIRING CLEARANCE						
Front		4" (101.6 mm)				
Top		4" (101.6 mm)				

## NT5010-DM2 DIMENSIONS In inches [mm]

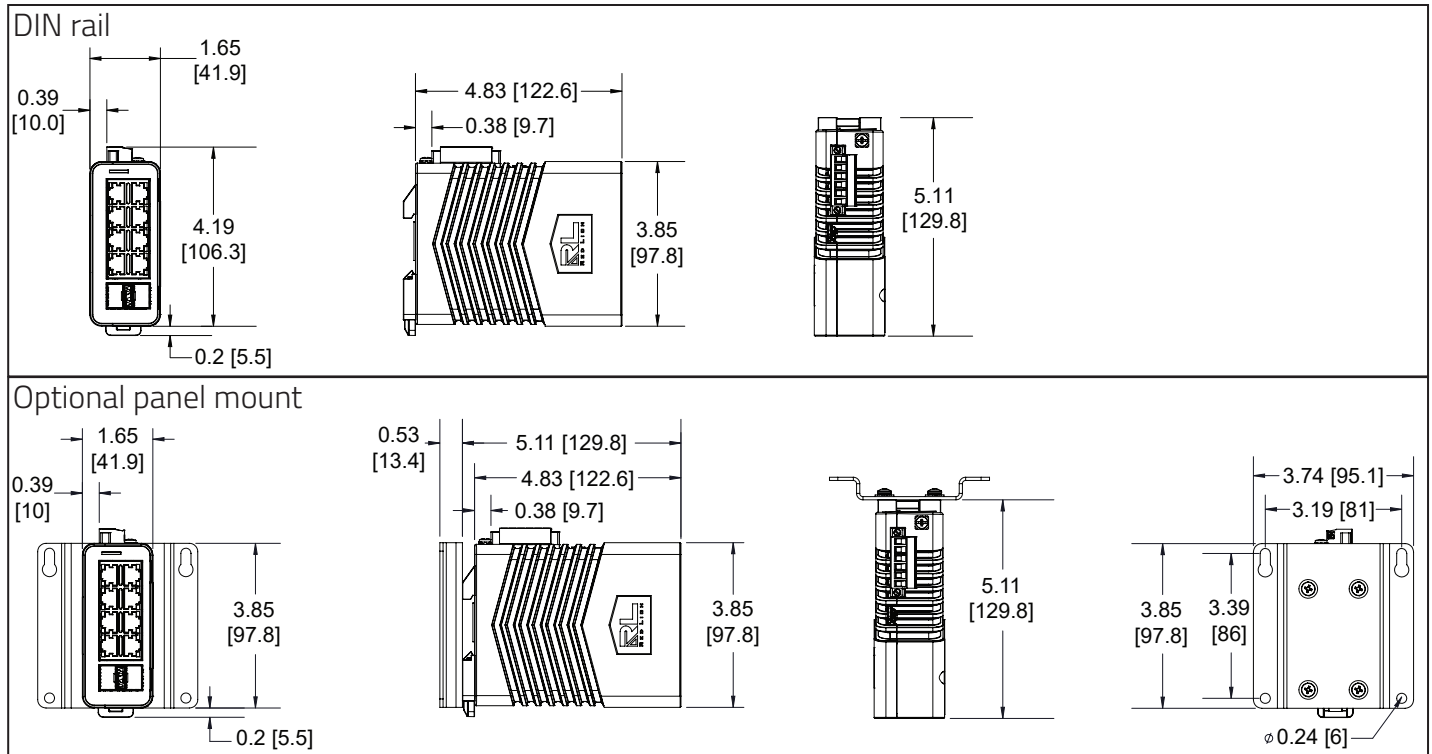

## NT5010-FX2 Specifications

MECHANICAL						
MTBF	Ingress Protection	Height	Width	Depth	Weight	Installation Options
1.2M Hours	IP20	3.85" (97.8 mm)	2.25" (57.1 mm)	5.11" (129.8 mm)	1.38 lbs. (0.62 kg)	DIN rail or optional panel mount
POWER INPUT						
Power Input Options	Input Voltage Range	Steady Input Range	BTU/hr			
Redundant Input Terminals; Reverse Polarity Protection	10-49 VDC	0.29 A @ 24 VDC	23.75			
ENVIRONMENTAL AND COMPLIANCES						
Operating Temperature Range	Storage Temperature Range	Humidity (non-condensing)	Operating Altitude			
-40 to 85 °C	-40 to 85 °C	10 to 95% RH	0 to 10,000 ft.			
SHOCK AND VIBRATION						
Shock			Vibration			
IEC 68-2-27: 200 g @ 10 ms Triaxial; non-operational; panel mounted			IEC 68-2-6: 15 g @ 5-200 Hz Triaxial; operational; panel mounted			
CONNECTORS						
10/100/1000BaseT	Eight (8) RJ45 copper ports					
100Base Fiber	Two (2) SC or ST duplex fiber ports					
NETWORK MEDIA						
10BaseT	≥Cat3 Cable					
100BaseTX	≥Cat5 Cable					
1000BaseT	≥Cat5e Cable					
100BaseFX Multimode	50-62.5/125 μm					
100BaseFX Singlemode	7-10/125 μm					
NETWORK THROUGHPUT						
Maximum Throughput	Up to 16.4 Gb/s					
MAC ADDRESSES						
MAC Address Support	Up to 4k					
RECOMMENDED MINIMUM WIRING CLEARANCE						
Front	4" (101.6 mm)					
Top	4" (101.6 mm)					

## NT5010-FX2 DIMENSIONS In inches [mm]

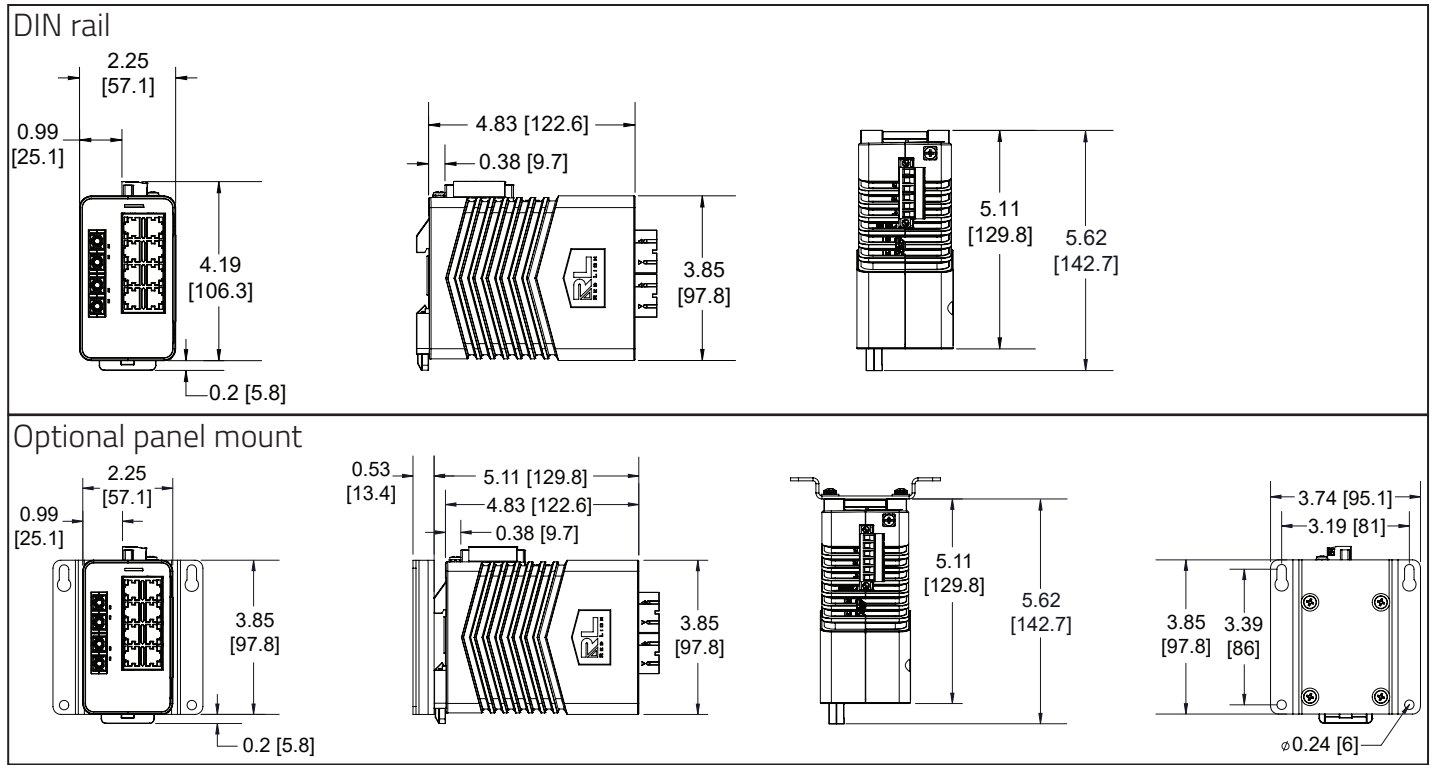

## NT5010-GX2 Specifications

MECHANICAL						
MTBF	Ingress Protection	Height	Width	Depth	Weight	Installation Options
1.2M Hours	IP20	3.85" (97.8 mm)	2.25" (57.1 mm)	5.11" (129.8 mm)	1.38 lbs. (0.62 kg)	DIN rail or optional panel mount
POWER INPUT						
Power Input Options	Input Voltage Range	Steady Input Range	BTU/hr			
Redundant Input Terminals; Reverse Polarity Protection	10-49 VDC	0.29 A @ 24 VDC	23.75			
ENVIRONMENTAL AND COMPLIANCES						
Operating Temperature Range	Storage Temperature Range	Humidity (non-condensing)	Operating Altitude			
-40 to 85 °C	-40 to 85 °C	10 to 95% RH	0 to 10,000 ft.			
SHOCK AND VIBRATION						
Shock			Vibration			
IEC 68-2-27: 200 g @ 10 ms Triaxial; non-operational; panel mounted			IEC 68-2-6: 15 g @ 5-200 Hz Triaxial; operational; panel mounted			
CONNECTORS						
10/100/1000BaseT	Eight (8) RJ45 copper ports					
1000Base Fiber	Two (2) SC duplex fiber ports					
NETWORK MEDIA						
10BaseT	≥Cat3 Cable					
100BaseTX	≥Cat5 Cable					
1000BaseT	≥Cat5e Cable					
1000BaseFX Multimode	50-62.5/125 μm					
1000BaseFX Singlemode	7-10/125 μm					
NETWORK THROUGHPUT						
Maximum Throughput	Up to 20.0 Gb/s					
MAC ADDRESSES						
MAC Address Support	Up to 4k					
RECOMMENDED MINIMUM WIRING CLEARANCE						
Front	4" (101.6 mm)					
Top	4" (101.6 mm)					

## NT5010-GX2 DIMENSIONS In inches [mm]

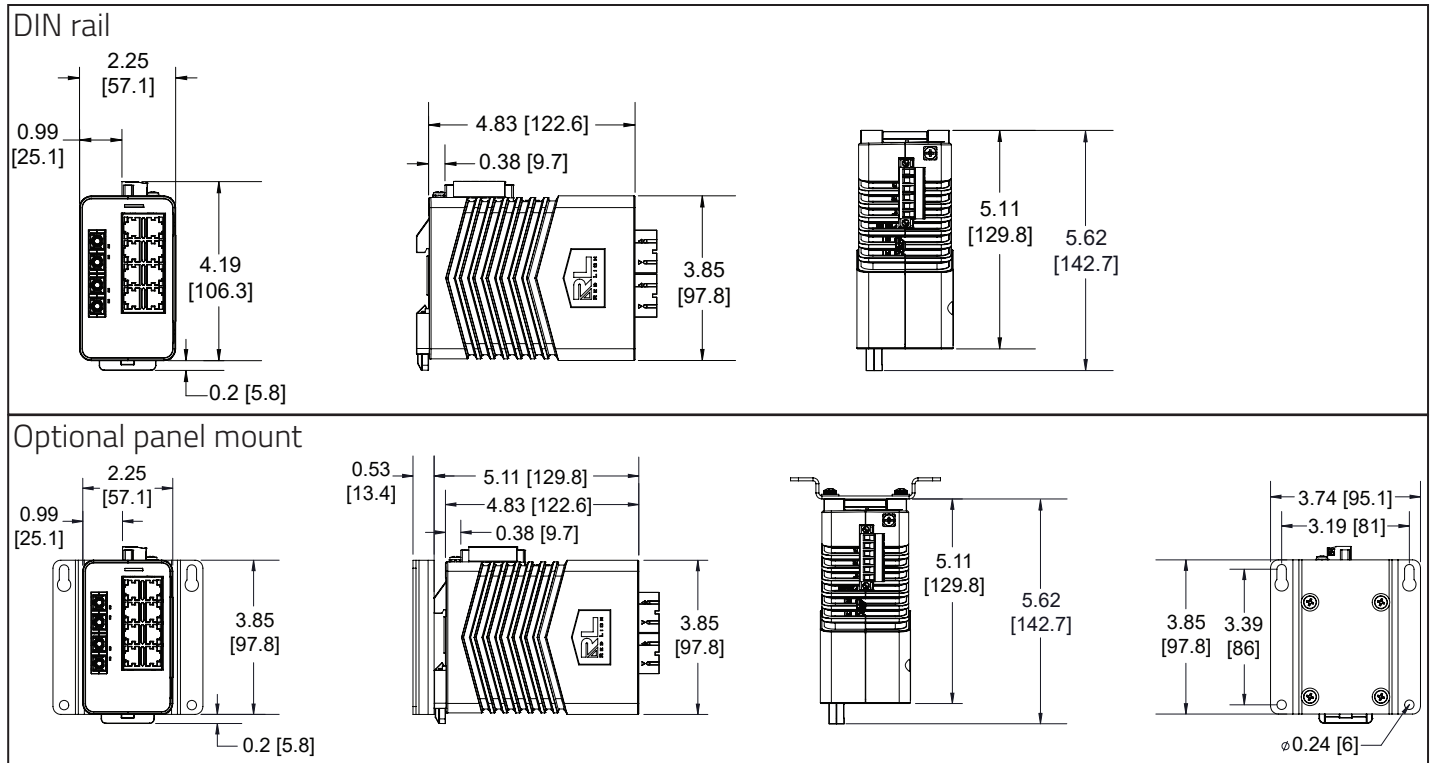

## NT5016 Specifications

MECHANICAL						
MTBF	Ingress Protection	Height	Width	Depth	Weight	Installation Options
1.2M Hours	IP20	5.36" (136.1 mm)	2.25" (57.1 mm)	5.11" (129.8 mm)	1.31 lbs. (0.60 kg)	DIN rail or optional panel mount
POWER INPUT						
Power Input Options	Input Voltage Range	Steady Input Range	BTU/hr			
Redundant Input Terminals; Reverse Polarity Protection	10-49 VDC	0.46 A @ 24 VDC	37.67			
ENVIRONMENTAL AND COMPLIANCES						
Operating Temperature Range	Storage Temperature Range	Humidity (non-condensing)	Operating Altitude			
-40 to 80 °C	-40 to 85 °C	10 to 95% RH	0 to 10,000 ft.			
SHOCK AND VIBRATION						
Shock			Vibration			
IEC 68-2-27: 200 g @ 10 ms Triaxial; non-operational; panel mounted			IEC 68-2-6: 15 g @ 5-200 Hz Triaxial; operational; panel mounted			
CONNECTORS						
10/100/1000BaseT	Sixteen (16) RJ45 copper ports					
NETWORK MEDIA						
10BaseT	≥Cat3 Cable					
100BaseTX	≥Cat5 Cable					
1000BaseT	≥Cat5e Cable					
NETWORK THROUGHPUT						
Maximum Throughput	Up to 32.0 Gb/s					
MAC ADDRESSES						
MAC Address Support	Up to 8k					
RECOMMENDED MINIMUM WIRING CLEARANCE						
Front	2" (50.8 mm)					
Top	4" (101.6 mm)					

## NT5016 DIMENSIONS In inches [mm]

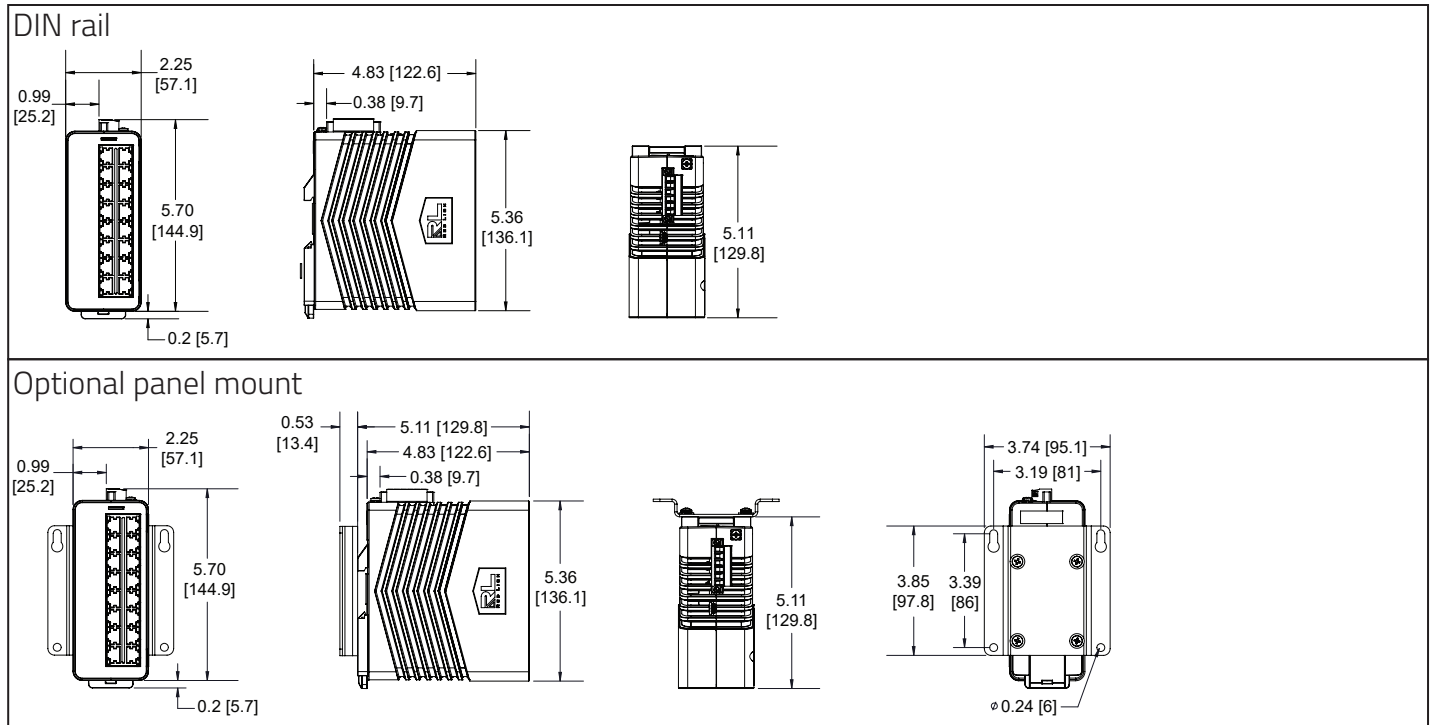



## NT5018-DM2 Specifications

MECHANICAL						
MTBF	Ingress Protection	Height	Width	Depth	Weight	Installation Options
1.2M Hours	IP20	5.36" (136.1 mm)	2.25" (57.1 mm)	5.11" (129.8 mm)	1.36 lbs. (0.62 kg)	DIN rail or optional panel mount
POWER INPUT						
Power Input Options	Input Voltage Range	Steady Input Range	BTU/hr			
Redundant Input Terminals; Reverse Polarity Protection	10-49 VDC	0.58 A @ 24 VDC	47.5			
ENVIRONMENTAL AND COMPLIANCES						
Operating Temperature Range	Storage Temperature Range	Humidity (non-condensing)	Operating Altitude			
-40 to 80 °C	-40 to 85 °C	10 to 95% RH	0 to 10,000 ft.			
SHOCK AND VIBRATION						
Shock			Vibration			
IEC 68-2-27: 200 g @ 10 ms Triaxial; non-operational; panel mounted			IEC 68-2-6: 15 g @ 5-200 Hz Triaxial; operational; panel mounted			
CONNECTORS						
10/100/1000BaseT		Sixteen (16) RJ45 copper ports				
Dual Mode 100/1000Base SFP Port		Up to two (2) SFP port transceivers (SFP transceivers sold separately)				
NETWORK MEDIA						
10BaseT		≥Cat3 Cable				
100BaseTX		≥Cat5 Cable				
1000BaseT		≥Cat5e Cable				
100BaseFX, 1000BaseSX Multimode		50-62.5/125µm				
100BaseFX, 1000BaseLX Singlemode		7-10/125µm				
NETWORK THROUGHPUT						
Maximum Throughput		Up to 36.0 Gb/s				
MAC ADDRESSES						
MAC Address Support		Up to 8k				
RECOMMENDED MINIMUM WIRING CLEARANCE						
Front		4" (101.6 mm)				
Top		4" (101.6 mm)				

## NT5018-DM2 DIMENSIONS In inches [mm]

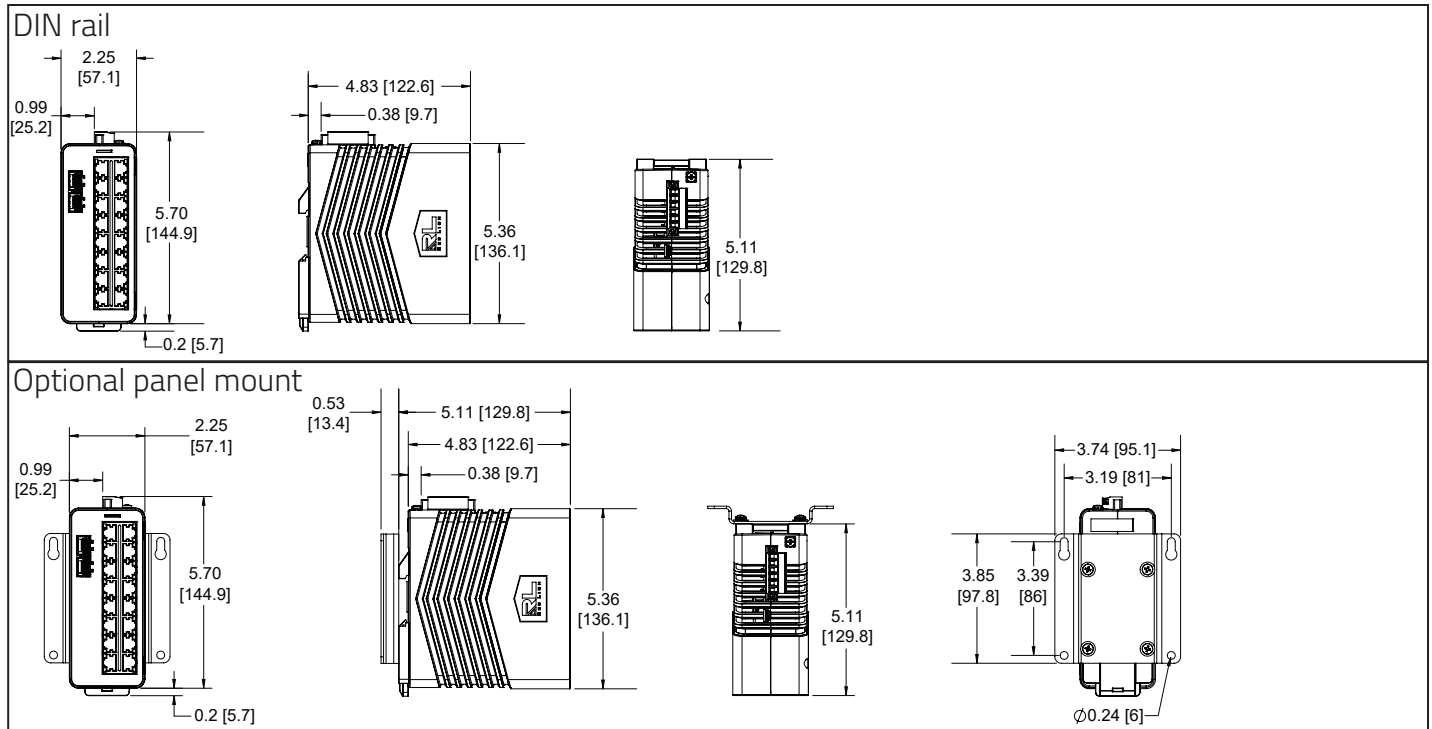

## NT5018-FX2 Specifications

MECHANICAL						
MTBF	Ingress Protection	Height	Width	Depth	Weight	Installation Options
1.2M Hours	IP20	5.36" (136.1 mm)	2.25" (57.1 mm)	5.11" (129.8 mm)	1.63 lbs. (0.74 kg)	DIN rail or optional panel mount
POWER INPUT						
Power Input Options	Input Voltage Range	Steady Input Range	BTU/hr			
Redundant Input Terminals; Reverse Polarity Protection	10-49 VDC	0.52 A @ 24 VDC	42.58			
ENVIRONMENTAL AND COMPLIANCES						
Operating Temperature Range	Storage Temperature Range	Humidity (non-condensing)	Operating Altitude			
-40 to 80 °C	-40 to 85 °C	10 to 95% RH	0 to 10,000 ft.			
SHOCK AND VIBRATION						
Shock			Vibration			
IEC 68-2-27: 200 g @ 10 ms Triaxial; non-operational; panel mounted			IEC 68-2-6: 15 g @ 5-200 Hz Triaxial; operational; panel mounted			
CONNECTORS						
10/100/1000BaseT	Sixteen (16) RJ45 copper ports					
100Base Fiber	Two (2) SC or ST duplex fiber ports					
10BaseT	≥Cat3 Cable					
100BaseTX	≥Cat5 Cable					
1000BaseT	≥Cat5e Cable					
100BaseFX Multimode	50-62.5/125 μm					
100BaseFX Singlemode	7-10/125 μm					
NETWORK THROUGHPUT						
Maximum Throughput	Up to 32.4 Gb/s					
MAC ADDRESSES						
MAC Address Support	Up to 8k					
RECOMMENDED MINIMUM WIRING CLEARANCE						
Front	4" (101.6 mm)					
Top	4" (101.6 mm)					

## NT5018-FX2 DIMENSIONS In inches [mm]

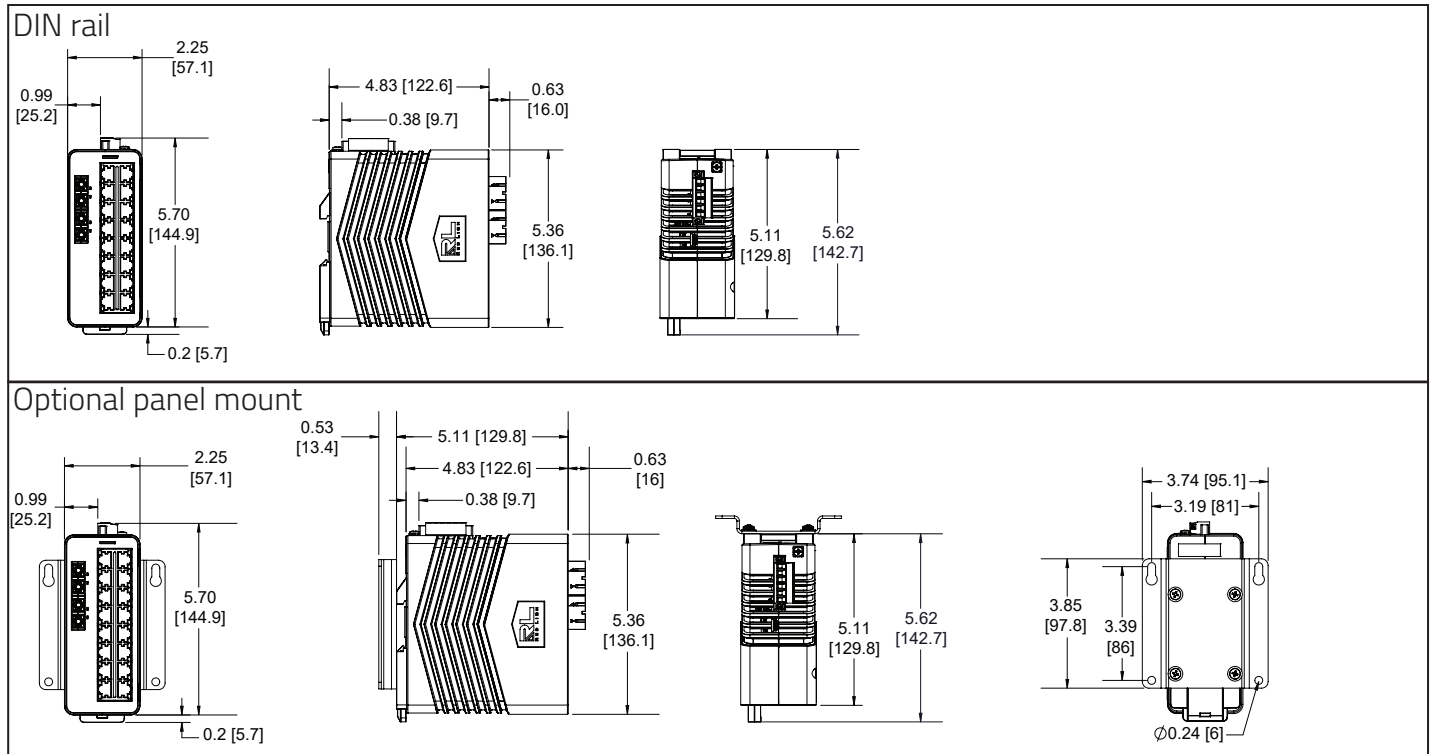

## NT5018-GX2 Specifications

MECHANICAL						
MTBF	Ingress Protection	Height	Width	Depth	Weight	Installation Options
1.2M Hours	IP20	5.36" (136.1 mm)	2.25" (57.1 mm)	5.11" (129.8 mm)	1.63 lbs. (0.74 kg)	DIN rail or optional panel mount
POWER INPUT						
Power Input Options	Input Voltage Range	Steady Input Range	BTU/hr			
Redundant Input Terminals; Reverse Polarity Protection	10-49 VDC	0.52 A @ 24 VDC	42.58			
ENVIRONMENTAL AND COMPLIANCES						
Operating Temperature Range	Storage Temperature Range	Humidity (non-condensing)	Operating Altitude			
-40 to 80 °C	-40 to 85 °C	10 to 95% RH	0 to 10,000 ft.			
SHOCK AND VIBRATION						
Shock			Vibration			
IEC 68-2-27: 200 g @ 10 ms Triaxial; non-operational; panel mounted			IEC 68-2-6: 15 g @ 5-200 Hz Triaxial; operational; panel mounted			
CONNECTORS						
10/100/1000BaseT	Sixteen (16) RJ45 copper ports					
1000BaseFiber	Two (2) SC duplex fiber ports					
NETWORK MEDIA						
10BaseT	≥Cat3 Cable					
100BaseTX	≥Cat5 Cable					
1000BaseT	≥Cat5e Cable					
1000BaseFX Multimode	50-62.5/125 μm					
1000BaseFX Singlemode	7-10/125 μm					
NETWORK THROUGHPUT						
Maximum Throughput	Up to 36.0 Gb/s					
MAC ADDRESSES						
MAC Address Support	Up to 8k					
RECOMMENDED MINIMUM WIRING CLEARANCE						
Front	4" (101.6 mm)					
Top	4" (101.6 mm)					

## NT5018-GX2 DIMENSIONS In inches [mm]

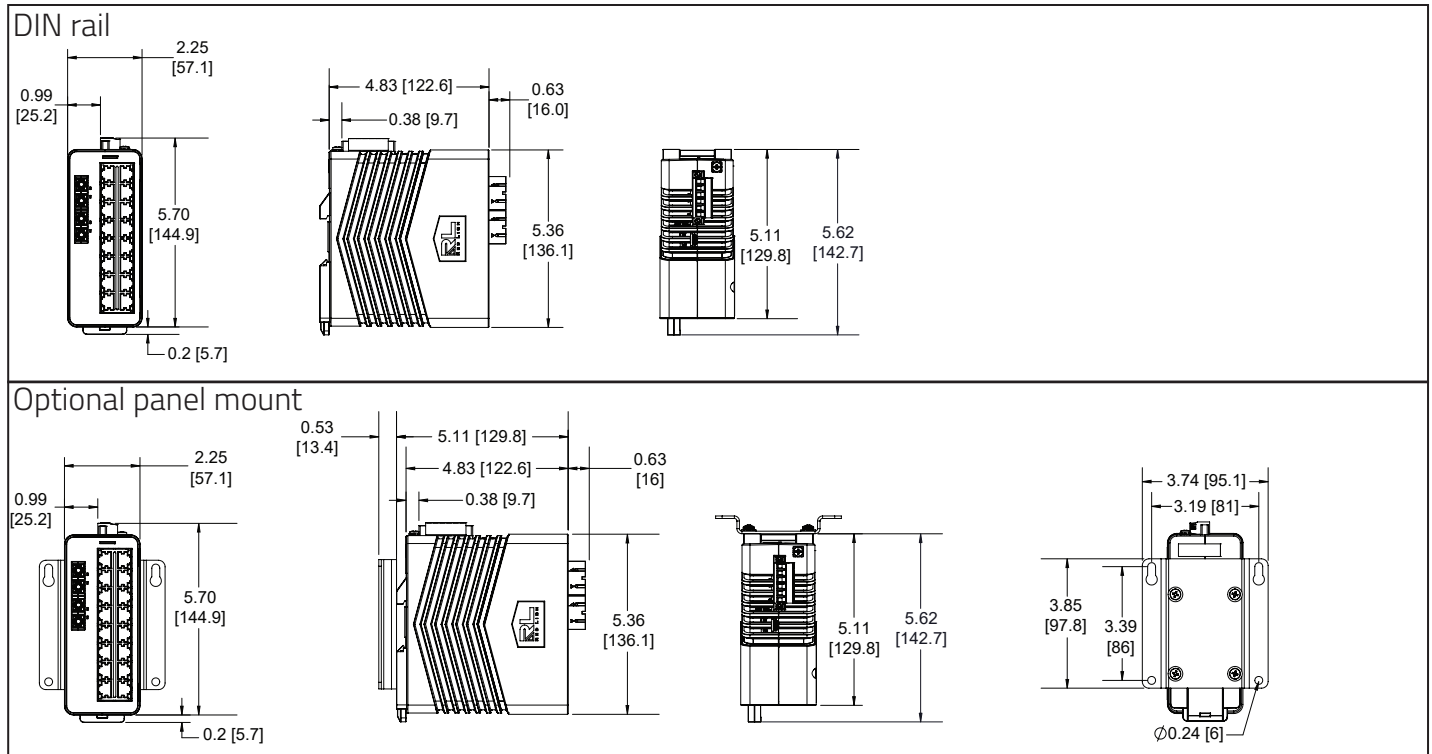

## LEDs

Data ports have two LEDs labeled LNK and ACT. The LNK LED indicates link and the ACT LED indicates port activity status.

The table below describes the operating modes:

LED	COLOR	DESCRIPTION
	Green	Power is On
	Red	Power is On and a fault condition exists
	Off	Power is Off
LNK	Green	10/100/1000 Mb Link between ports
	Off	No link between ports
ACT	Green	Data is active between ports. Activity light blink rate indicates activity, not necessarily the volume of activity.
	Off	Data is inactive between ports

## Transceiver Characteristics

The following table details the characteristics of integrated FX and GX transceivers, as well as the removable SFP transceivers (purchased separately).

### 100 MB Fiber Transceiver Characteristics (NT5008-FX2, NT5010-FX2, NT5018-FX2)

Fiber Mode	MM	SM	SM	SM
Fiber Length*	2 km	15 km	40 km	80 km
TX Power Min.	-19 dBm	-15 dBm	-5 dBm	-5 dBm
RX Sensitivity Max.	-31 dBm	-34 dBm	-34 dBm	-34 dBm
Wavelength	1310 nm	1310 nm	1310 nm	1550 nm

### Gigabit Fiber Transceiver Characteristics (NT5008-GX2, NT5010-GX2, NT5018-GX2)

Fiber Mode	MM	SM	SM	SM
Fiber Length*	550m @ 50/125 $\mu$ m 300m @ 62.5/125 $\mu$ m	10 km	40 km	80 km
TX Power Min.	-9.5 dBm	-9.5 dBm	-5 dBm	0 dBm
RX Sensitivity Max.	-17 dBm	-20 dBm	-23 dBm	-24 dBm
Wavelength	850 nm	1310 nm	1310 nm	1550 nm
Laser Type	VCSEL	FP	DFB	DFB

### SFP 100Base Fiber Transceiver Characteristics (NT5006-DM2, NT5008-DM2, NT5010-DM2, NT5018-DM2)

Fiber Mode	MM	SM	SM	SM
Fiber Length*	2 km	15 km	40 km	80 km
TX Power Min.	-19 dBm	-15 dBm	-5 dBm	-5 dBm
RX Sensitivity Max.	-31 dBm	-34 dBm	-34 dBm	-34 dBm
Wavelength	1310 nm	1310 nm	1310 nm	1550 nm
Laser Type	FP	FP	FP	DFB

### SFP 1000Base Fiber Transceiver Characteristics (NT5006-DM2, NT5008-DM2, NT5010-DM2, NT5018-DM2)

Fiber Mode	MM	SM	SM	SM
Fiber Length*	550 m @ 50/125 $\mu$ m 275 m @ 62.5/125 $\mu$ m	10 km	40 km	80 km
TX Power Min.	-9.5 dBm	-9.5 dBm	-2 dBm	0 dBm
RX Sensitivity Max.	-17 dBm	-20 dBm	-22 dBm	-24 dBm
Wavelength	850 nm	1310 nm	1310 nm	1550 nm
Laser Type	VCSEL	FP	DFB	DFB

\* Fiber Length distances represent typical performance. Link budgets should be evaluated based on specific application conditions.



# Chapter 2 Installation

## Contents of Package

Carefully remove the switch and accessories from the shipping container and inspect them for damage. Contact Red Lion immediately if any damage is discovered.

Please verify that the box contains the following items:

- NT5000 switch
- Quick Start Guide

## Mounting the NT5000 Unit

A clearance of one inch should be observed on the sides, back, top and bottom to allow proper ventilation. Also, the NT5000 requires a cable bend radius of two inches to be observed for the front and top side of the unit. Any fiber-optic cabling connected to the NT5000 will require a bend radius of at least four inches at the front of the unit.

For hazardous location installation, the following shall be taken into consideration:

- The equipment shall only be used in an area of at least pollution degree 2, as defined in EN 60664-1.
- The equipment shall be installed in an enclosure that provides a minimum ingress protection of IP54 in accordance with EN 60079-0. The enclosure shall be accessible only with the use of a tool.

## DIN Rail Mounting Instructions

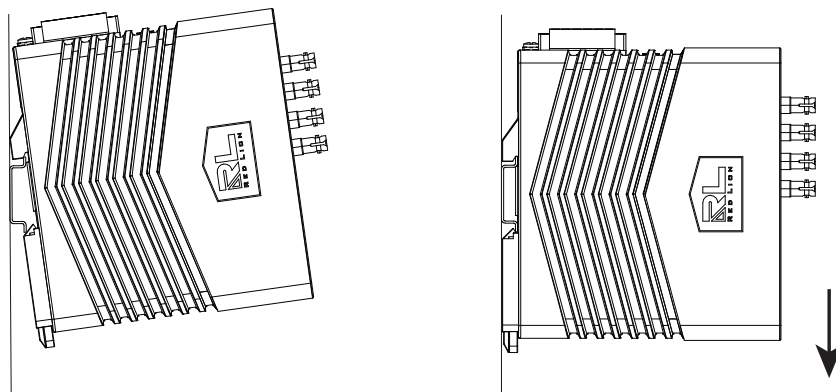

Install the switch to standard 35mm DIN rail as shown in the diagram above.

1. First, hook the top of the DIN rail clip on the back of the switch to the rail.
2. Then, gently rotate the front of the switch downward, towards the panel.
3. Push the bottom of the switch towards the rail until it locks into place.
4. Apply upward force to verify the switch is securely installed.
5. Connect any communications cables to the switch.
6. Install the power and ground wires.
7. Apply power to the power supply.

## DIN Rail Removal Instructions

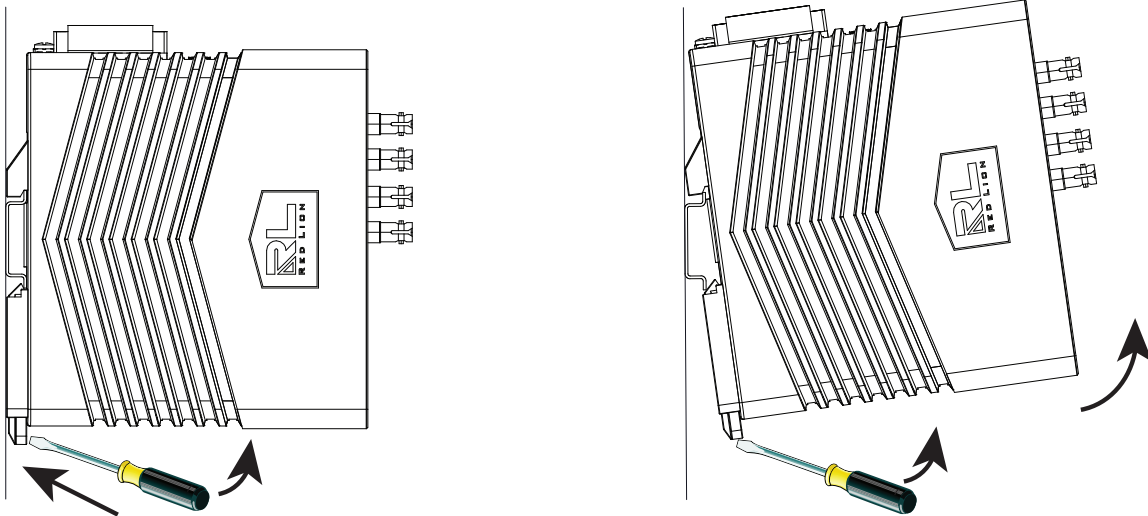

Remove the switch from standard 35mm DIN rail as shown in the diagram above.

1. Ensure power from the power source is off.
  2. Disconnect power and ground wires.
  3. Disconnect any communications cables from the unit.
  4. Insert a standard flat/slotted screwdriver into the slot provided on the DIN rail clip.
  5. Using the base of the switch as a pivot point, apply upward force on the screwdriver to release the DIN rail clip.
  6. With the DIN rail clip latching mechanism released, continue to rotate the switch upward and away from the panel.
  7. Once the switch has been rotated upward, remove the screwdriver.
- Carefully lift the switch upward and away from the DIN rail and panel.

## Panel Mounting NT5000 Models

### Optional panel mount

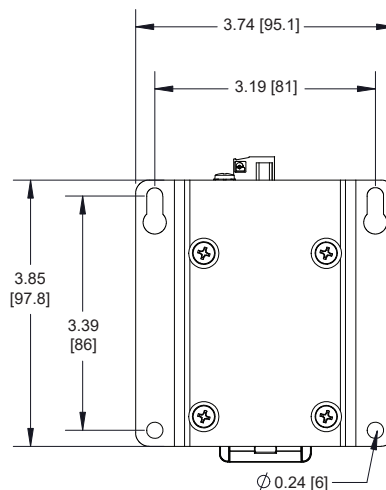
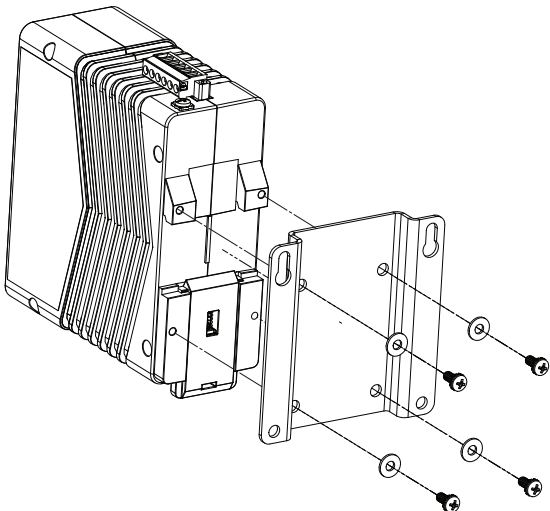

The NT5000 models are also designed for panel mounting. This section includes the mechanical dimensions and drill hole placements to consider when panel mounting the unit. For horizontal clearance in the installation location for cable bend radius, allow at least 2" for copper and 4" for fiber optic.

1. Screw the rugged panel bracket on with the screws in the accessory kit. Tighten screws with 6 in-lb torque.



**WARNING:** Panel mounting installation in non-hazardous locations only.

**AVERTISSEMENT:** Installation de montage sur panneau dans des endroits non dangereux uniquement.

## Power Source

The switch can be powered from two UL61010-2-201 certified SELV power supplies (input range 10 to 49 VDC). Unscrew and remove the DC voltage input plug from the power input header. Insert the positive and negative wires (AWG 12-20) into V+ and V- contact on the terminal block and tighten the wire-clamp screws. Tighten the wire-clamp screws with a torque value of 4.4 pound-force inch (0.5 Nm) to prevent the wires from being loosened. Verify that the power LED is on.

**Note:** The DC power should be connected to a well-fused power supply. Use 12AWG-20AWG wire and screw torque value 4.4 pound-force inch (0.5 Nm) for power connection.

**Note:** Use with Copper Conductors Only.

**Note:** Cable temperature rating is at least 90 degrees or more.

**Note:** The stripping length of the power cable is recommended to be 8-9 mm.

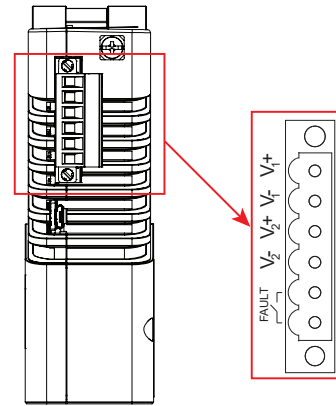



**WARNING:** Ensure that all power sources to the chassis (power distribution panel) are turned off during the connection.

**AVERTISSEMENT:** Assurez-vous que toutes les sources d'alimentation du châssis (panneau de distribution électrique) sont éteintes pendant la connexion.

**Note:** At least one DC power supply must be connected for operation. For redundant power operation, PWR1 and PWR2 inputs must be connected to separate DC voltage sources. This unit will draw power from the supply with higher voltage.

Recommended 24 VDC power supply, similar to Red Lion's P/N NTPS-24-1-3.

Verify that the proper input voltage is connected to the NT5000 before powering on the unit. **Applying AC power to a DC NT5000 unit will damage the unit.**

**Note:** LEDs are described in detail in "LEDs" on page 35.

## Connecting to Earth Ground

The grounding of any control system is an integral part of the design. The optimum noise immunity and emissions are obtained when the NT5000 chassis is connected to earth ground via a 12 gauge wire or better. The NT5000 units provide a grounding lug (see illustration) that is used to provide a safe grounding path of the device. Torque the screw to 4.4 pound-force inch (0.5 Nm) for grounding connection. Do not over-tighten the screw.

**Note:** The NT5000 power input (V-) pins are isolated from chassis ground. Do not attempt to ground the switch to earth ground via the power input pins (V-).

**Note:** Use with Copper Conductors Only.

**Note:** The stripping length of the grounding cable is recommended to be 8-9 mm.

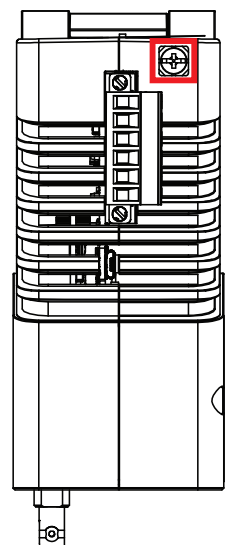

## Configurable Alarm Relay Contact

The alarm relay contact, located on the top of the NT5000, can be used to control an external warning device such as a light in order to provide an external alarm. The current carrying capacity is 1 A at 24 VDC. The relay is normally open and closes when a fault condition occurs. The conditions for generating a fault condition as well as reversing the default status to normally closed, can be configured via the software interface.

Refer to the NT5000 Software Guide for more information.

**Note:** Use with Copper Conductors Only.

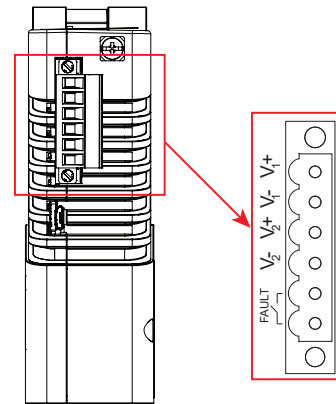

## Connecting to the Ethernet Port (RJ45 Ethernet)

For 10/100/1000BaseT(X) ports, plug a Category 5e twisted pair cable into the RJ45 connector. Connect the other end to the far end station. Verify that the LNK LEDs are ON once the connection has been completed. To connect any port to another device, use a standard Cat5e straight through or crossover cable with a minimum length of one meter and a maximum length of 100 meters.

Red Lion recommends the use of pre-manufactured Cat5e cables to ensure the best performance. If this is not an option and users must terminate their own ends on the Cat5e cables, one of the two color coded standards shown to the right should be utilized. If a user does not follow one of these standards, then the performance and maximum cable distance will be reduced significantly and may prevent the switch from establishing a link.

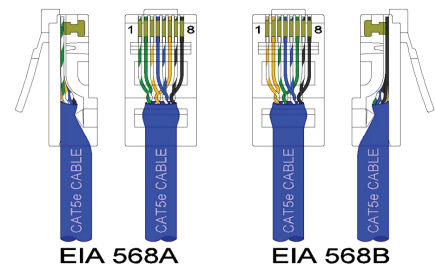



**WARNING:** Creating a network loop without employing a network path protocol such as RSTP is an illegal operation that can create a network storm which will crash the network.

**AVERTISSEMENT:** La création d'un réseau sans boucle employant un chemin réseau protocole tels que RSTP est une opération illégale que peut créer une tempête du réseau qui va planter le réseau.

PIN #	ASSIGNMENT
1,2	T/RxA+,T/RxA-
3,6	T/RxB+,T/RxB-
4,5	T/RxC+,T/RxC-
7,8	T/RxD+,T/RxD-



## Connecting to the Ethernet Port (Fiber, SFP)

For FX/GX models, remove the dust cap from the fiber optic connectors and connect the appropriate fiber optic cables. The TX port on the FX/GX models should be connected to the RX port of the far end station. The RX port on the FX/GX models should be connected to the TX port of the far end station.

For available 100/1000Base SFP transceivers, see the Accessories table.

The connectors are available with multimode or singlemode transceivers.

The Optical Transceiver must use a UL Certified Class 1 laser product that shall comply with CDRH 21CFR 1040.10 and 1040.11.

	<b>DANGER:</b> Never attempt to view optical connectors that might be emitting laser energy. Do not power up the laser product without connecting the laser to the optical fiber and putting the cover in position, as laser outputs will emit infrared laser light at this point.
	<b>AVERTISSEMENT:</b> N'essayez jamais de voir des connecteurs optiques susceptibles d'émettre de l'énergie laser. Ne mettez pas le produit laser sous tension sans connecter le laser à la fibre optique et mettre le capot en place, car les sorties laser émettent une lumière laser infrarouge à ce stade.

## USB Interface

The NT5000 switches provide a USB interface accessed via the Micro-B USB connector on the top of the unit. The USB connection is used to access the Command Line Interpreter (CLI). In order to use the USB interface to access the CLI, the CP210x USB to UART Bridge VCP Drivers must be installed. These drivers can be obtained directly from Silicon Labs' website.

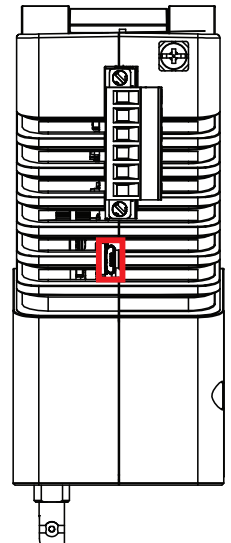

## USB Cable

Connect the USB port of your PC and the Switch using a standard USB cable. A cable with a Type A connector for the PC end, and a Micro-B USB connector for the switch end must be used.

Standard USB-A to Micro-B USB cables are readily available from a variety of computer stores.

## Terminal

The following configuration should be used in terminal emulation program:

- USB-A to Micro-B USB Cable to connect to computer USB port
- Port Settings: 115200 bps
- Data Bits: 8
- Parity: None
- Stop Bits: 1
- Flow Control: None



**WARNING:** The console connection is for temporary connection only. Do not use, connect, or disconnect unless the area is known to be non-hazardous. Connection or disconnection in an explosive atmosphere could result in an explosion.

**AVERTISSEMENT:** La connection à la console est pour la connexion temporaire seulement. Ne pas utiliser, connecter ou déconnecter sauf si la zone est connue pour être non dangereuse. Connexion ou la déconnexion dans une atmosphère explosive pourrait entraîner une explosion.

## Cleaning

Clean only with a damp cloth. Excess moisture or harsh chemicals can cause damage to the unit.

# Chapter 3 Accessing the Web Software Interface

1. Launch a web browser and enter the IP address of the device into the address bar. By default, the DHCP Client is enabled and if DHCP times out the device can be reached using the fallback address 192.168.1.201.
2. The following login screen will appear.

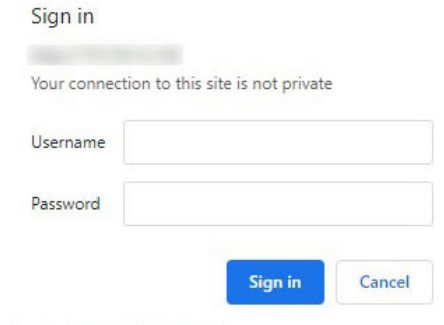

3. Enter the Username: default is **admin** (all lowercase).
4. Enter the Password: there is no default.  
**Note:** For security purposes, a password must be set on first logon. The user will be prompted to set a password. Canceling this step will not allow access to the device.
5. Upon successfully logging in, depending on the unit used, a screen similar to the one below will appear:

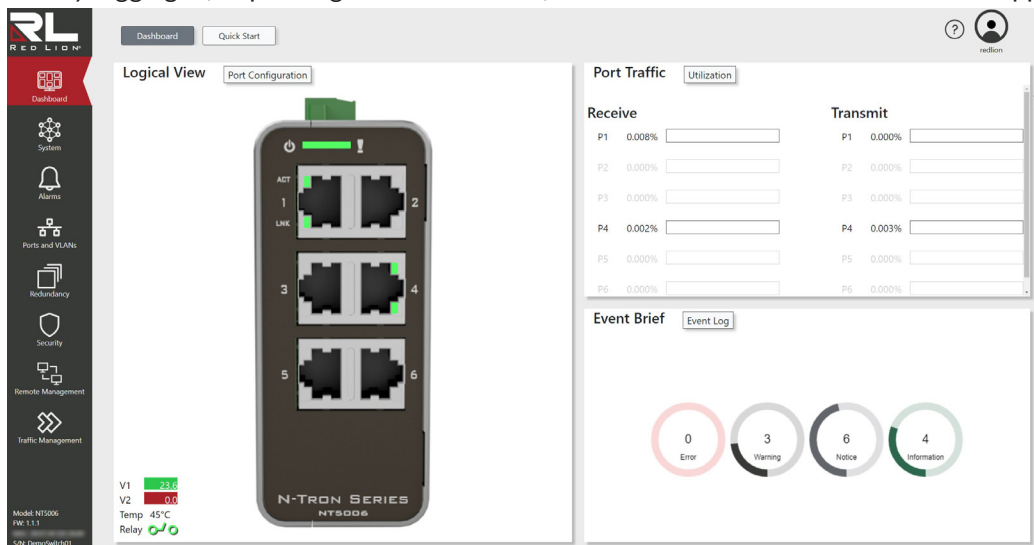

Please consult the NT5000 Software Guide for configuration options.

## Ordering Information

PART NUMBER	DESCRIPTION
NT-5006-000-0000	6-Port Gigabit Managed Industrial Ethernet Switch (6 10/100/1000BaseT RJ45 Ports)
NT-5006-DM2-0000	6-Port Gigabit Managed Industrial Ethernet Switch (4 10/100/1000BaseT RJ45 Ports, 2 Dual Mode 100/1000Base SFP Expansion Slots)
NT-5008-000-0000	8-Port Gigabit Managed Industrial Ethernet Switch (8 10/100/1000BaseT RJ45 Ports)
NT-5008-DM2-0000	8-Port Gigabit Managed Industrial Ethernet Switch (6 10/100/1000BaseT RJ45 Ports, 2 Dual Mode 100/1000Base SFP Expansion Slots)
NT-5008-FX2-SC00	8-Port Gigabit Managed Industrial Ethernet Switch (6 10/100/1000BaseT RJ45 Ports, 2 100BaseFX, Multimode, 2km, SC Style Connector)
NT-5008-FX2-SC15	8-Port Gigabit Managed Industrial Ethernet Switch (6 10/100/1000BaseT RJ45 Ports, 2 100BaseFX, Singlemode, 15km, SC Style Connector)
NT-5008-FX2-SC40	8-Port Gigabit Managed Industrial Ethernet Switch (6 10/100/1000BaseT RJ45 Ports, 2 100BaseFX, Singlemode, 40km, SC Style Connector)
NT-5008-FX2-SC80	8-Port Gigabit Managed Industrial Ethernet Switch (6 10/100/1000BaseT RJ45 Ports, 2 100BaseFX, Singlemode, 80km, SC Style Connector)
NT-5008-FX2-ST00	8-Port Gigabit Managed Industrial Ethernet Switch (6 10/100/1000BaseT RJ45 Ports, 2 100BaseFX, Multimode, 2km, ST Style Connector)
NT-5008-FX2-ST15	8-Port Gigabit Managed Industrial Ethernet Switch (6 10/100/1000BaseT RJ45 Ports, 2 100BaseFX, Singlemode, 15km, ST Style Connector)
NT-5008-FX2-ST40	8-Port Gigabit Managed Industrial Ethernet Switch (6 10/100/1000BaseT RJ45 Ports, 2 100BaseFX, Singlemode, 40km, ST Style Connector)
NT-5008-FX2-ST80	8-Port Gigabit Managed Industrial Ethernet Switch (6 10/100/1000BaseT RJ45 Ports, 2 100BaseFX, Singlemode, 80km, ST Style Connector)
NT-5008-GX2-SC00	8-Port Gigabit Managed Industrial Ethernet Switch (6 10/100/1000BaseT RJ45 Ports, 2 1000BaseSX, Multimode, 550m, SC Style Connector)
NT-5008-GX2-SC10	8-Port Gigabit Managed Industrial Ethernet Switch (6 10/100/1000BaseT RJ45 Ports, 2 1000BaseLX, Singlemode, 10km, SC Style Connector)
NT-5008-GX2-SC40	8-Port Gigabit Managed Industrial Ethernet Switch (6 10/100/1000BaseT RJ45 Ports, 2 1000BaseLX, Singlemode, 40km, SC Style Connector)
NT-5008-GX2-SC80	8-Port Gigabit Managed Industrial Ethernet Switch (6 10/100/1000BaseT RJ45 Ports, 2 1000BaseLX, Singlemode, 80km, SC Style Connector)
NT-5010-DM2-0000	10-Port Gigabit Managed Industrial Ethernet Switch (8 10/100/1000BaseT RJ45 Ports, 2 Dual Mode 100/1000Base SFP Expansion Slots)
NT-5010-FX2-SC00	10-Port Gigabit Managed Industrial Ethernet Switch (8 10/100/1000BaseT RJ45 Ports, 2 100BaseFX, Multimode, 2km, SC Style Connector)
NT-5010-FX2-SC15	10-Port Gigabit Managed Industrial Ethernet Switch (8 10/100/1000BaseT RJ45 Ports, 2 100BaseFX, Singlemode, 15km, SC Style Connector)
NT-5010-FX2-SC40	10-Port Gigabit Managed Industrial Ethernet Switch (8 10/100/1000BaseT RJ45 Ports, 2 100BaseFX, Singlemode, 40km, SC Style Connector)
NT-5010-FX2-SC80	10-Port Gigabit Managed Industrial Ethernet Switch (8 10/100/1000BaseT RJ45 Ports, 2 100BaseFX, Singlemode, 80km, SC Style Connector)
NT-5010-FX2-ST00	10-Port Gigabit Managed Industrial Ethernet Switch (8 10/100/1000BaseT RJ45 Ports, 2 100BaseFX, Multimode, 2km, ST Style Connector)
NT-5010-FX2-ST15	10-Port Gigabit Managed Industrial Ethernet Switch (8 10/100/1000BaseT RJ45 Ports, 2 100BaseFX, Singlemode, 15km, ST Style Connector)
NT-5010-FX2-ST40	10-Port Gigabit Managed Industrial Ethernet Switch (8 10/100/1000BaseT RJ45 Ports, 2 100BaseFX, Singlemode, 40km, ST Style Connector)
NT-5010-FX2-ST80	10-Port Gigabit Managed Industrial Ethernet Switch (8 10/100/1000BaseT RJ45 Ports, 2 100BaseFX, Singlemode, 80km, ST Style Connector)
NT-5010-GX2-SC00	10-Port Gigabit Managed Industrial Ethernet Switch (8 10/100/1000BaseT RJ45 Ports, 2 1000BaseSX, Multimode, 550m, SC Style Connector)



PART NUMBER	DESCRIPTION
NT-5010-GX2-SC10	10-Port Gigabit Managed Industrial Ethernet Switch (8 10/100/1000BaseT RJ45 Ports, 2 1000BaseLX, Singlemode, 10km, SC Style Connector)
NT-5010-GX2-SC40	10-Port Gigabit Managed Industrial Ethernet Switch (8 10/100/1000BaseT RJ45 Ports, 2 1000BaseLX, Singlemode, 40km, SC Style Connector)
NT-5010-GX2-SC80	10-Port Gigabit Managed Industrial Ethernet Switch (8 10/100/1000BaseT RJ45 Ports, 2 1000BaseLX, Singlemode, 80km, SC Style Connector)
NT-5016-000-0000	16-Port Gigabit Managed Industrial Ethernet Switch (16 10/100/1000BaseT RJ45 Ports)
NT-5018-DM2-0000	18-Port Gigabit Managed Industrial Ethernet Switch (16 10/100/1000BaseT RJ45 Ports, 2 Dual Mode 100/1000Base SFP Expansion Slots)
NT-5018-FX2-SC00	18-Port Gigabit Managed Industrial Ethernet Switch (16 10/100/1000BaseT RJ45 Ports, 2 100BaseFX, Multimode, 2km, SC Style Connector)
NT-5018-FX2-SC15	18-Port Gigabit Managed Industrial Ethernet Switch (16 10/100/1000BaseT RJ45 Ports, 2 100BaseFX, Singlemode, 15km, SC Style Connector)
NT-5018-FX2-SC40	18-Port Gigabit Managed Industrial Ethernet Switch (16 10/100/1000BaseT RJ45 Ports, 2 100BaseFX, Singlemode, 40km, SC Style Connector)
NT-5018-FX2-SC80	18-Port Gigabit Managed Industrial Ethernet Switch (16 10/100/1000BaseT RJ45 Ports, 2 100BaseFX, Singlemode, 80km, SC Style Connector)
NT-5018-FX2-ST00	18-Port Gigabit Managed Industrial Ethernet Switch (16 10/100/1000BaseT RJ45 Ports, 2 100BaseFX, Multimode, 2km, ST Style Connector)
NT-5018-FX2-ST15	18-Port Gigabit Managed Industrial Ethernet Switch (16 10/100/1000BaseT RJ45 Ports, 2 100BaseFX, Singlemode, 15km, ST Style Connector)
NT-5018-FX2-ST40	18-Port Gigabit Managed Industrial Ethernet Switch (16 10/100/1000BaseT RJ45 Ports, 2 100BaseFX, Singlemode, 40km, ST Style Connector)
NT-5018-FX2-ST80	18-Port Gigabit Managed Industrial Ethernet Switch (16 10/100/1000BaseT RJ45 Ports, 2 100BaseFX, Singlemode, 80km, ST Style Connector)
NT-5018-GX2-SC00	18-Port Gigabit Managed Industrial Ethernet Switch (16 10/100/1000BaseT RJ45 Ports, 2 1000BaseSX, Multimode, 550m, SC Style Connector)
NT-5018-GX2-SC10	18-Port Gigabit Managed Industrial Ethernet Switch (16 10/100/1000BaseT RJ45 Ports, 2 1000BaseLX, Singlemode, 10km, SC Style Connector)
NT-5018-GX2-SC40	18-Port Gigabit Managed Industrial Ethernet Switch (16 10/100/1000BaseT RJ45 Ports, 2 1000BaseLX, Singlemode, 40km, SC Style Connector)
NT-5018-GX2-SC80	18-Port Gigabit Managed Industrial Ethernet Switch (16 10/100/1000BaseT RJ45 Ports, 2 1000BaseLX, Singlemode, 80km, SC Style Connector)

Model number may be followed by -CC indicating conformal coating.

## Accessories

PART NUMBER	DESCRIPTION
NT-CPMA-03-00000	NT5000 Panel Mount Kit, Type A (Wide) Models: NT5008-FX2, NT5008-GX2, NT5010-FX2, NT5010-GX2, NT5016, NT5018-DM2, NT5018-FX2, NT5018-GX2
NT-CPMA-04-00000	NT5000 Panel Mount Kit, Type B (Narrow) Models: NT5006, NT5006-DM2, NT5008, NT5008-DM2, NT5010-DM2
NTPS-24-1-3	DIN Rail Power Supply, 1.3 Amp @ 24 VDC
NTSFP-FX	100BaseFX Multimode Fiber SFP Transceiver (LC Style Connector, 2km)
NTSFP-FXE-15	100BaseFX Singlemode Fiber SFP Transceiver (LC Style Connector, 15km)
NTSFP-FXE-40	100BaseFX Singlemode Fiber SFP Transceiver (LC Style Connector, 40km)
NTSFP-FXE-80	100BaseFX Singlemode Fiber SFP Transceiver (LC Style Connector, 80km)

PART NUMBER	DESCRIPTION
NTSFP-SX	1000BaseSX Multimode Fiber SFP Transceiver (LC Style Connector, 550m)
NTSFP-LX-10	1000BaseLX Singlemode Fiber SFP Transceiver (LC Style Connector, 10km)
NTSFP-LX-40	1000BaseLX Singlemode Fiber SFP Transceiver (LC Style Connector, 40km)
NTSFP-LX-80	1000BaseLX Singlemode Fiber SFP Transceiver (LC Style Connector, 80km)
NTSFP-TX	1000BaseT Copper SFP Transceiver (RJ45 Connector)

# Service and Support Information

## Service Information

We sincerely hope that you never experience a problem with any of our products. If you do need service, call Red Lion at 1-877-432-9908 for Technical Support. A trained specialist will help you determine the source of the problem. Many problems are easily resolved with a single phone call. If it is necessary to return a unit to us, an RO (Repair Order) can be obtained on the Red Lion website.

Red Lion tracks the flow of returned material with our RO system to ensure speedy service. You must include this RO number on the outside of the box so that your return can be processed immediately.

Be sure to have your original purchase order number and date purchased available.

We suggest that you give us a repair purchase order number in case the repair is not covered under our warranty. You will not be billed if the repair is covered under warranty.

Please supply us with as many details about the problem as you can. The information you supply will be written on the RO form and supplied to the repair department before your unit arrives. This helps us to provide you with the best service, in the fastest manner. Repairs are completed as soon as possible. If you need a quicker turnaround, ship the unit to us by air freight. We give priority service to equipment that arrives by overnight delivery.

We apologize for any inconvenience that the need for repair may cause you. We hope that our rapid service meets your needs. If you have any suggestions to help us improve our service, please give us a call. We appreciate your ideas and will respond to them.

## For Your Convenience:

Please fill in the following and keep this manual with your Red Lion system for future reference.

P.O. #: \_\_\_\_\_ Date Purchased: \_\_\_\_\_  
Purchased From: \_\_\_\_\_  
Serial Number: \_\_\_\_\_

## Product Support

### Technical Support:

Inside US: +1 (877) 432-9908  
Outside US: +1 (717) 767-6511  
Support: [support.redlion.net](http://support.redlion.net)  
Hours: 8:00 am to 6:00 pm EST

Red Lion Controls  
35 Willow Springs Circle  
York, PA 17406  
Website: [www.redlion.net](http://www.redlion.net)

## LIMITED WARRANTY

(a) Red Lion Controls Inc. (the "Company") warrants that all Products shall be free from defects in material and workmanship under normal use for the period of time provided in "Statement of Warranty Periods" (available at [www.redlion.net](http://www.redlion.net)) current at the time of shipment of the Products (the "Warranty Period"). **EXCEPT FOR THE ABOVE-STATED WARRANTY, COMPANY MAKES NO WARRANTY WHATSOEVER WITH RESPECT TO THE PRODUCTS, INCLUDING ANY (A) WARRANTY OF MERCHANTABILITY; (B) WARRANTY OF FITNESS FOR A PARTICULAR PURPOSE; OR (C) WARRANTY AGAINST INFRINGEMENT OF INTELLECTUAL PROPERTY RIGHTS OF A THIRD PARTY; WHETHER EXPRESS OR IMPLIED BY LAW, COURSE OF DEALING, COURSE OF PERFORMANCE, USAGE OF TRADE OR OTHERWISE.** Customer shall be responsible for determining that a Product is suitable for Customer's use and that such use complies with any applicable local, state or federal law.

(b) The Company shall not be liable for a breach of the warranty set forth in paragraph (a) if (i) the defect is a result of Customer's failure to store, install, commission or maintain the Product according to specifications; (ii) Customer alters or repairs such Product without the prior written consent of Company.

(c) Subject to paragraph (b), with respect to any such Product during the Warranty Period, Company shall, in its sole discretion, either (i) repair or replace the Product; or (ii) credit or refund the price of Product provided that, if Company so requests, Customer shall, at Company's expense, return such Product to Company.

(d) **THE REMEDIES SET FORTH IN PARAGRAPH (c) SHALL BE THE CUSTOMER'S SOLE AND EXCLUSIVE REMEDY AND COMPANY'S ENTIRE LIABILITY FOR ANY BREACH OF THE LIMITED WARRANTY SET FORTH IN PARAGRAPH (a).**

**BY INSTALLING THIS PRODUCT, YOU AGREE TO THE TERMS OF THIS WARRANTY, AS WELL AS ALL OTHER DISCLAIMERS AND WARRANTIES IN THIS DOCUMENT.**